

WEEE MARK

En If you want to dispose this product, do not mix with general household waste. There is a separate collection systems for used electronics products in accordance with legislation under the WEEE Directive (Directive 2002/96/EC) and is effective only within European Union.

Ge Wenn Sie dieses Produkt entsorgen wollen, dann tun Sie dies bitte nicht zusammen mit dem Haushaltsmüll. Es gibt im Rahmen der WEEE-Direktive innerhalb der Europäischen Union (Direktive 2002/96/EC) gesetzliche Bestimmungen für separate Sammelsysteme für gebrauchte elektronische Geräte und Produkte.

Fr Si vous souhaitez vous débarrasser de cet appareil, ne le mettez pas à la poubelle avec vos ordures ménagères. Il existe un système de récupération distinct pour les vieux appareils électroniques conformément à la législation WEEE sur le recyclage des déchets des équipements électriques et électroniques (Directive 2002/96/EC) qui est uniquement valable dans les pays de l'Union européenne.

Les appareils et les machines électriques et électroniques contiennent souvent des matières dangereuses pour l'homme et l'environnement si vous les utilisez et vous vous en débarrassez de façon inappropriée.

Sp Si desea deshacerse de este producto, no lo mezcle con residuos domésticos de carácter general. Existe un sistema de recogida selectiva de aparatos electrónicos usados, según establece la legislación prevista por la Directiva 2002/96/CE sobre residuos de aparatos eléctricos y electrónicos (RAEE), vigente únicamente en la Unión Europea.

It Se desiderate gettare via questo prodotto, non mescolatelo ai rifiuti generici di casa. Esiste un sistema di raccolta separato per i prodotti elettronici usati in conformità alla legislazione RAEE (Direttiva 2002/96/CE), valida solo all'interno dell'Unione Europea.

Du Deponeer dit product niet bij het gewone huishoudelijk afval wanneer u het wilt verwijderen. Er bestaat ingevolge de WEEE-richtlijn (Richtlijn 2002/96/EG) een speciaal wettelijk voorgeschreven verzamelsysteem voor gebruikte elektronische producten, welk alleen geldt binnen de Europese Unie.

Da Hvis du vil skille dig af med dette produkt, må du ikke smide det ud sammen med dit almindelige husholdningsaffald. Der findes et separat indsamlingssystem for udtjente elektroniske produkter i overensstemmelse med lovgivningen under WEEE-direktivet (direktiv 2002/96/EC), som kun er gældende i den Europæiske Union.

Por Se quiser deitar fora este produto, não o misture com o lixo comum. De acordo com a legislação que decorre da Directiva REEE – Resíduos de Equipamentos Eléctricos e Electrónicos (2002/96/CE), existe um sistema de recolha separado para os equipamentos electrónicos fora de uso, em vigor apenas na União Europeia.

Pol Jeżeli zamierzasz pozbyć się tego produktu, nie wyrzucaj go razem ze zwykłymi domowymi odpadkami. Według dyrektywy WEEE (Dyrektywa 2002/96/EC) obowiązującej w Unii Europejskiej dla używanych produktów elektronicznych należy stosować oddzielne sposoby utylizacji.

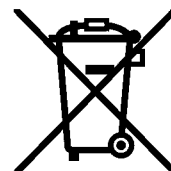

Declaration of Conformity

This printer conforms to the following Standards:

Low Voltage Directive 73/23/EEC, 93/68/EEC and the EMC Directive 89/336/EEC, 92/31/EEC, 93/68/EEC.

LVD : EN60950

EMC : EN55022 Class A

EN61000-3-2

EN61000-3-3

EN55024

This declaration is applied only for 230V model.

WARNING : This is a Class A products. In a domestic environment this product may cause radio interference in which case the user may be required to take adequate measures.

CITIZEN is a registered trade mark of CITIZEN WATCH CO., LTD., Japan
CITIZEN es una marca registrada de CITIZEN WATCH CO., LTD., Japón

IMPORTANT SAFETY INSTRUCTIONS

- Read all of these instructions and save them for future reference.
- Follow all warnings and instructions marked on the product.
- Unplug this product from the wall outlet before cleaning. Do not use liquid or aerosol cleaners. Use a damp cloth for cleaning.
- Do not use this product near water.
- Do not place this product on an unstable cart, stand or table. The product may fall, causing serious damage to the product.
- Slots and openings on the back or bottom of the case are provided for ventilation. To ensure reliable operation of the product and to protect it from overheating, do not block or cover these openings. The openings should never be blocked by placing the product on a bed, sofa, rug or other similar surface. This product should never be placed near or over a radiator or heater. This product should not be placed in an built-in installation unless proper ventilation is provided.
- This product should be operated from the type of power source indicated on the marking label. If you are not sure of the type of power available, consult your dealer or local power company.
- Do not allow anything to rest on the power cord. Do not place this product where the cord will be walked on.
- If an extension cord is used with this product, make sure that the total of the ampere ratings of the products plugged into the extension cord does not exceed the extension cord ampere rating. Also, make sure that the total of all products plugged into the wall outlet does not exceed 15 amperes.
- Never push objects of any kind into this product through cabinet slots as they may touch dangerous voltage points or short out parts that could result in a risk of fire or electric shock. Never spill liquid of any kind on the product.
- Except as explained elsewhere in this manual, do not attempt to service this product by yourself. Opening and removing the covers that are marked "Do Not Remove" may expose you to dangerous voltage points or other risks. Refer all servicing on those compartments to service personnel.
- Unplug this product from the wall outlet and refer servicing to qualified service personnel under the following conditions:
 - A. When the power cord or plug is damaged or frayed.
 - B. If liquid has been spilled into the product.
 - C. If the product has been exposed to rain or water.
 - D. If the product does not operate normally when the operating instructions are followed. Adjust only those controls that are covered by the operating instructions since improper adjustment of other controls may result in damage and will often require extensive work by a qualified technician to restore the product to normal operation.
 - E. If the product has been dropped or the cabinet has been damaged.
 - F. If the product exhibits a distinct change in performance, indicating a need for service.
- Please keep the poly bag which this equipment is packed in away from children or throw it away to prevent children from putting it on. Putting it on may cause suffocation.

WICHTIGE SICHERHEITSANWEISUNGEN

- Lesen Sie die nachfolgenden Anweisungen sorgfältig durch und bewahren Sie sie auf.
- Befolgen Sie alle auf dem Drucker vermerkten Hinweise und Anweisungen. Vor dem Reinigen grundsätzlich Stecker aus der Steckdose ziehen. Keine Flüssigkeiten oder Aerosolreiniger benutzen. Nur mit einem feuchten Tuch abwischen.
- Der Drucker darf nicht in der Nähe von Wasser aufgestellt werden.
- Drucker nicht auf einem unstabilen Wagen, Stand oder Tisch aufstellen. Der Drucker könnte herunterfallen und dabei beschädigt werden.
- Schlitze und Öffnungen im Gehäuse, in der Rückwand und im Boden dienen der Belüftung. Sie dürfen keinesfalls zugedeckt oder blockiert werden, da sich der Drucker sonst überhitzt. Drucker nicht auf ein Bett, Sofa, Teppich oder dergleichen stellen. Drucker nicht in der Nähe eines Heizkörpers aufstellen. Drucker darf nicht eingebaut werden, falls nicht für ausreichende Belüftung gesorgt ist.
- Drucker nur mit der auf dem Typschild angegebenen Spannung betreiben. Wenn Sie sich nicht sicher sind, fragen Sie ihren Händler oder ihr zuständiges Elektrizitätswerk.
- Nichts auf das Stromanschlußkabel stellen. Kabel muß so verlegt werden, daß man nicht darauf treten kann.
- Ein etwaiges Verlängerungskabel muß der Stromstärke aller daran angeschlossenen Geräte entsprechen.
- Keine Gegenstände in die Gehäuseschlitze schieben.
- Drucker darf nur da gewartet werden, wo im Handbuch angegeben, Öffnen und. Abnehmen von Abdeckungen, die mit "Do not remove" gekennzeichnet sind, könnte gefährliche spannungführende Stellen oder sonstige Gefahrenpunkte freilegen. Die Wartung solcher Stellen darf grundsätzlich nur von besonders ausgebildetem Fachpersonal vorgenommen werden.
 - A. Wenn das Stromanschlußkabel oder der Stecker beschädigt oder durch-gescheuert ist.
 - B. Wenn Flüssigkeit auf dem Drucker verschüttet wurde.
 - C. Wenn der Drucker im Regen gestanden hat oder Wasser darauf verschüttet wurde.
 - D. Wenn der Drucker trotz genauer Befolgung der Betriebsvorschriften nicht richtig arbeitet. Nur die in der Bedienungsanleitung angegebenen Einstellungen vornehmen. Ein Verstellen anderer Bedienelemente könnte den Drucker beschädigen und macht umständliche Arbeiten eines qualifizierten Technikers erforderlich, um den Drucker wieder auf den normalen Betrieb einzustellen.
 - E. Wenn der Drucker heruntergefallen ist oder das Gehäuse beschädigt wurde.
 - F. Wenn der Drucker in seiner Leistung nachläßt.
- Bitte halten Sie den Kunststoffbeutel, in den die Ware verpackt ist, von Kindern entfernt, oder werfen Sie ihn weg, damit er nicht in die Hände von Kindern gerät. Das Überstülpen des Beutels kann zum Ersticken führen.

Lärmemission kleiner 70dBA

IMPORTANT: This equipment generates, uses, and can radiate radio frequency energy and if not installed and used in accordance with the instruction manual, may cause interference to radio communications. It has been tested and found to comply with the limits for a Class A computing device pursuant to Subpart J of Part 15 of FCC Rules, which are designed to provide reasonable protection against such interference when operated in a commercial environment. Operation of this equipment in a residential area is likely to cause interference, in which case the user at his own expense will be required to take whatever measures may be necessary to correct the interference.

CAUTION: Use shielded cable for this equipment.

Sicherheitshinweis

Die Steckdose zum Anschluß dieses Druckers muß nahe dem Gerät angebracht und leicht zugänglich sein.

For Uses in Canada

This digital apparatus does not exceed the class A limits for radio noise emissions from digital, apparatus, as set out in the radio interference regulations of the Canadian department of communications.

Pour L'utilisateurs Canadiens

Cet appareil numérique ne dépasse pas les limites de catégorie a pour les émissions de bruit radio émanant d'appareils numériques, tel que prévu dans les règlements sur l'interférence radio du département Canadien des communications.

<CAUTIONS>

1. Prior to using the equipment, be sure to read this User's Manual thoroughly. Please keep it handy for reference whenever it may be needed.
2. The information contained herein may be changed without prior notice.
3. Reproduction of part or all of this User's Manual without permission is strictly prohibited.
4. Never service, disassemble, or repair parts that are not mentioned in this User's Manual.
5. Note that we will not be responsible for damages attributable to a user's incorrect operation/ handling or an improper operating environment.
6. Operate the equipment only as described in this User's Manual; otherwise accidents or problems may result.
7. Data are basically temporary; they cannot be stored or saved permanently or for a long time. Please note that we will not be responsible for damages or losses of profit resulting from losses of the data attributable to accidents, repairs, tests, and so on.
8. If you have any questions or notice any clerical errors or omissions regarding the information in this manual, please contact our office.
9. Please note that, notwithstanding Item 8 above, we will not be responsible for any effects resulting from operation of the equipment.

SAFETY PRECAUTIONS ----- BE SURE TO OBSERVE

In order to prevent hazards to an operator or other persons and damage to property, be sure to observe the following precautions.

- The following describes the degrees of hazard and damages that can occur if the given instructions are neglected or the equipment is incorrectly operated.

**WARNING**

Negligence of this precaution may result in death or serious injury.

**CAUTION**

Negligence of this precaution may result in injury or damage to property.



This is an illustration mark used to alert your attention.



This is an illustration mark used to indicate such information as an instruction or the like.

 **WARNING**

- Never handle the equipment in the following manners, as it may break, become out of order, or overheat causing smoke and resulting in fire or electric shock. If the equipment is used in an abnormal condition, such as when broken, then problems, smoke emission, abnormal odor/noise, and fire can result. If an abnormal condition exists, be sure to disconnect the power plug from a plug socket, and contact our dealer. Never repair the equipment on your own - it is very dangerous.
- Do not allow the equipment to receive a strong impact or shock, such as kicking, stomping, hitting, dropping, and the like.
- Install the equipment in a well-ventilated place. Do not use it in such a manner that its ventilation port will be blocked.
- Do not install the equipment in a place like a laboratory where chemical reactions are expected, or in a place where salt or gases are contained in the air.
- Do not connect/disconnect a power cord or a data cable, while holding the cable. Do not pull, install, use, or carry the equipment in such a manner that force will be applied to the cables.
- Do not drop or insert any foreign substances, such as clips or pins, into the equipment.
- Do not spill any liquid or spray any chemical-containing liquid over the equipment. If any liquid is spilled on it, turn off the power, disconnect the power cable and power cord from the plug socket, and so on, and contact our dealer.
- Never disassemble or remodel the equipment. Negligence of this may cause fire or electric shock.
- Use the equipment only with the specified commercial power supply and AC adapter. Negligence of this may result in fire, electric shock, or problems.
- If you drop or break the AC adapter, or if water or the like gets inside it, unplug it immediately from the socket and contact your dealer.
- Do not damage, break, process, bend/pull by force, twist, or head an AC adapter cord. Also, do not put a heavy substance on it or heat it. The AC adapter cord could be broken, resulting in fire, electric shock, or trouble. If the AC adapter cord is damaged, contact our dealer.
- Do not connect/disconnect the AC adapter with wet hands.
- Do not overload a single electrical outlet, using a table tap or a current tap socket.
- An equipment packing bag must be discarded or kept away from children. A child can suffocate if the bag is placed over the head.



PRECAUTIONS FOR INSTALLATION

- Do not use or store the equipment in a place exposed to fire, moisture, or direct sunshine, or in a place near a heater or thermal device where the prescribed operating temperature and humidity are not met, or in a place exposed to much oil, iron powder, or dust. The equipment may become out of order, emit smoke, or catch fire.
- Do not install or use the equipment in a place like a laboratory where chemical reactions are expected, or in a place where salt or gases are contained in the air. There is a danger of fire or electric shock.
- Install the printer on a flat, stable desk or table that is free from vibration, in a well-ventilated place.
- Do not install the printer at a location where its operation could be hindered.
- Do not place anything on the printer or leave small objects, like a clip or pin, around it. A foreign object could cause trouble if it gets inside.
- Do not use any sharp-pointed object, such as a pen, for example, to touch the operation panel of the printer. It could cause trouble.
- Do not use the equipment near a radio or TV receiver. Do not share the power from a plug socket a radio or TV receiver is connected to. It may cause a reception problem.
- Use the equipment only at the specified power supply, voltage and frequency. Otherwise, it may emit smoke and catch fire or cause other problems.
- Connect only the specified power source. Use of an unspecified power source could cause trouble or smoke/fire.
- Confirm that a plug socket used for connection has sufficient capacity.
- Avoid connecting a power cable to a plug socket shared by other devices or extending the wiring too far. It may result in the cable catching fire or a power outage. Also, do not step on or apply an excessive force (Pull, load) to the cable, and do not use the printer with such a force applied to it.
- Never connect a grounding cable (Frame ground) to a gas pipe. There is a danger of explosion. When connecting or disconnecting the grounding cable, be sure to disconnect the power cable and the power plug from the plug socket.
- When connecting/disconnecting the cables, be sure to turn off the power first, including the connected side, and then connect/disconnect them, holding a plug and a connector. Pulling the cable itself could cause it to snap or become damaged.
- Connect a power cable or a connector cable securely. If a reverse-polarity connection is made, internal elements may be broken or a mating device may be adversely affected.
- Use a shielding wire or twisted pair wire for a signal line, in order to minimize noise effect. Do not route the cable too long or connect it to a noisy device. Connection to a noisy device could cause erroneous printing due to corrupt data, and so on.
- Use the equipment in an environment where there is a plug socket near the main body and you can easily disconnect the power plug from it, to shut off the power.
- When the equipment will not be used for a long period of time, unplug it and remove the paper roll from it.
- When transporting the equipment, remove the paper roll from the paper holder.



PRECAUTIONS FOR HANDLING

Do not handle the equipment in the following manners, because problems may result.

- Do not use any other power source besides the accessory AC adapter. Also, do not use the AC adapter for other purposes.
- Do not print without paper.
- Do not drop or put any foreign object, such as a clip, pin, or the like, inside the printer.
- Do not spill any liquid or spray any chemical-containing liquid over the equipment.
- Never use a pointed object, such as a pen, to operate the operation panel.
- Do not use Scotch tape to fasten paper together for continuous use. It could damage the printing head.
- Never pull the set paper forcibly. When opening/closing the printer cover, take care that the paper will not be caught. It could cause the paper to jam.
- Be sure to use the specified paper. Use of other paper could deteriorate the print quality or cause a problem with the printing head.

To Prevent Injury and Spreading of Damage

- Never touch the printing head, motor, or paper cutting blade. Your finger may be cut.
- During power-on or immediately after printing, do not touch electrical parts or moving parts, such as the mechanism, motor, internal gear, etc. They may be very hot and can burn your hand/finger.
- Be careful to avoid bodily injure or damaging other objects with an edge of sheet metal.
- Should any error occur while operating the equipment, stop it immediately and disconnect the power plug from the plug socket.
- Only a qualified serviceman is allowed to disassemble or repair the printer.
- Should a problem occur, leave solving it to our serviceman. Do not disassemble the equipment on your own.
- When opening/closing the printer cover, and so on, be careful not to catch your hand or finger on the equipment.
- After using the equipment, turn off the power switch and unplug the AC adapter from a plug socket.

DAILY MAINTENANCE

- At the time of maintenance, be sure to turn off the power switch of the printer and unplug it from the socket.
- Use a dry soft cloth to wipe off stains and dust from the surfaces of the main body case. For severe soiling, dip the cloth in water and wring it, for wiping off the soil. Never use organic solvents, such as alcohol, thinner, trichlene, benzene, ketone, or chemical dusters.
- If the equipment is contaminated with paper powder, use a soft brush to clean it. Be careful not to damage the printing head.

 **CAUTION:** The printing head and motor are very hot. Be careful not to touch them immediately after printing. Do not touch the heating surface of the head with a bare hand or metal.

● Cleaning the Printing Head

1. Referring to "4.5 Removing Paper Jam," detach the platen roller unit.
2. Moisten gauze slightly with alcohol, and clean the heating surface of the printing head with it.
3. Reattach the platen roller unit.

 **CAUTION:** The printing head and motor are very hot. Be careful not to touch them immediately after printing. Do not touch the heating surface of the head with a bare hand or metal. When detaching or reattaching the platen roller unit, be sure to raise up the printing head; otherwise, they could be damaged. Handle the detached platen roller unit carefully so as not to damage it.

CONTENTS

1. OUTLINE	1
1.1 Features.....	1
1.2 Unpacking.....	1
2. BASIC SPECIFICATIONS	2
2.1 Model Classifications	2
2.2 Basic Specifications.....	3
2.3 Paper Specifications.....	4
2.3.1 Recommended Paper	4
2.3.2 Printing Position	5
2.3.3 Head and Paper Cutter Layout.....	5
3. OUTER APPEARANCE AND COMPONENT PARTS.....	6
4. OPERATION.....	8
4.1 Connecting AC Adapter	8
4.2 Connecting Interface Cable	9
4.3 Inserting the Paper	10
4.4 How to Remove Remaining Paper Roll.....	11
4.5 Eliminating the Paper Jam	12
4.6 FEED Switch Function	13
4.6.1 When Thermal Paper is Used	13
4.6.2 When Label Paper is Used.....	13
4.6.3 When the Macro is Executed	13
4.6.4 When the Label is Fed to the Paper Cutting Position by the Command.....	13
4.7 Paper End Function.....	13
4.8 Paper Near End Function.....	14
4.9 Auto-Loading Function	15
4.10 Self-Print Function.....	15
4.11 Operation Panel and Display of Error.....	16
4.12 Red/Black Print (Precautions for use).....	17
5. DIP SWITCH SETTING	18
5.1 Location of DIP Switch	18
5.2 DIP Switch Function.....	18
5.3 Jumper Wire Function	19

6. PARALLEL INTERFACE	20
6.1 Specifications.....	20
6.2 Connector's Pin Configuration.....	20
6.3 Input and Output Signals	20
6.3.1 Input and Output Signals	20
6.3.2 Electrical Characteristics	21
6.3.3 Timing Chart.....	22
6.3.4 Data Receiving Control	22
6.3.5 Buffering.....	22
7. SERIAL INTERFACE.....	23
7.1 Specifications.....	23
7.2 Connector's Pin Configuration.....	23
7.3 Input and Output Signals	24
7.3.1 Input and Output Signals	24
7.3.2 Data Configuration	25
7.3.3 Error Detection	25
7.3.4 Data Receiving Control	26
7.3.5 Buffering.....	26
7.3.6 Electrical Characteristics	26
8. POWER CONNECTOR.....	27
9. MAINTENANCE AND SERVICE	28
10. PRINT CONTROL FUNCTIONS.....	29
10.1 Command List	29
10.2 Command Details	31
10.2.1 Descriptions of Each Items	31
10.2.2 Command Details	32
11. CHARACTER CODES TABLE	73
11.1 International.....	73
11.2 Domestic	73
11.3 International Character Codes Table.....	74

APPENDIX 1. BLOCK DIAGRAM	75
APPENDIX 2. DRAWING	76
APPENDIX 3. WALL MOUNTING HOLES LAYOUT DRAWING	77

<<< German >>>

4. BETRIEB	85
4.1 Anschließen des Netzteils	85
4.2 Anschließen des Schnittstellenkabels	86
4.3 Einsetzen des Papiers	87
4.4 Entnehmen der eingesetzten Papierrolle	88
4.5 Beheben von Papierstau	89
4.6 FEED-Schalterfunktion	90
4.6.1 Bei Verwendung von Thermalpapier	90
4.6.2 Bei Verwendung von Etikettenpapier	90
4.6.3 Bei Ausführung eines Makros	90
4.6.4 Wenn das Etikett mit Befehl bis zur Papierschneideposition vorgeschoben wird	90
4.7 Papierende-Funktion	90
4.8 Papiermangel-Funktion	90
4.9 Autoladefunktion	91
4.10 Selbstdruckfunktion	92
4.11 Bedienfeld und Fehleranzeigen	92
4.12 Rot/Schwalts-Druck(Vorsichtsmaßregeln):	94
5. DIP-SCHALTEREINSTELLUNG	95
5.1 Lage der DIP-Schalter	95
5.2 DIP-Schalterfunktion	95
5.3 Jumperdraht-Funktion	96
9. WARTUNG UND KUNDENDIENST	97

1. OUTLINE

This small line thermal printer is designed for various types of data communication terminals and measuring instrument terminals. Its abundant built-in features allow you to widely use this printer for different applications. Prior to using it, read and understand this manual thoroughly.

1.1 Features

1. Small, lightweight, and installable in a narrow area
2. High speed and low noise, owing to line thermal print
3. Long-life printing head and high reliability, owing to the simple mechanism
4. Easy paper-loading, owing to the auto-loading function
5. Built-in input buffer
6. Capable of printing a bar code (Special command)
7. Capable of accommodating both thermal paper and label paper
8. A little discharge (1 sheet) of the label paper at power-on or paper replacement
9. Capable of printing in two colors (when special paper is used)
10. External characters registration function(94 kanji characters, 95 ANK characters)

1.2 Unpacking

When unpacking the package, confirm that the following parts are provided:

- Printer body ----- 1 unit
- Sample paper roll ----- 1 roll
- AC adapter ----- 1 piece
- AC cord ----- 1 piece
- User's manual ----- 1 copy

CAUTION

- Install the printer body on a flat and stable desk or mount it onto the wall, etc., using a hook, etc.
- Do not install the printer near a heater or in a place exposed to the direct sunshine.
- Do not use the printer in a high-temperature, high-humidity, or contaminated environment.
- Do not allow dew condensation to form on the printer. If such condensation should form, do not turn on the power until it has completely gone away.
- Use only the accessory AC adapter. Do not use it for any other purpose.
- If you do not use the printer for a long period, disconnect the power cable from the socket.
- Keep this manual carefully at hand for ready reference.

2. BASIC SPECIFICATIONS

2.1 Model Classifications

The models are classified by the following designation method:

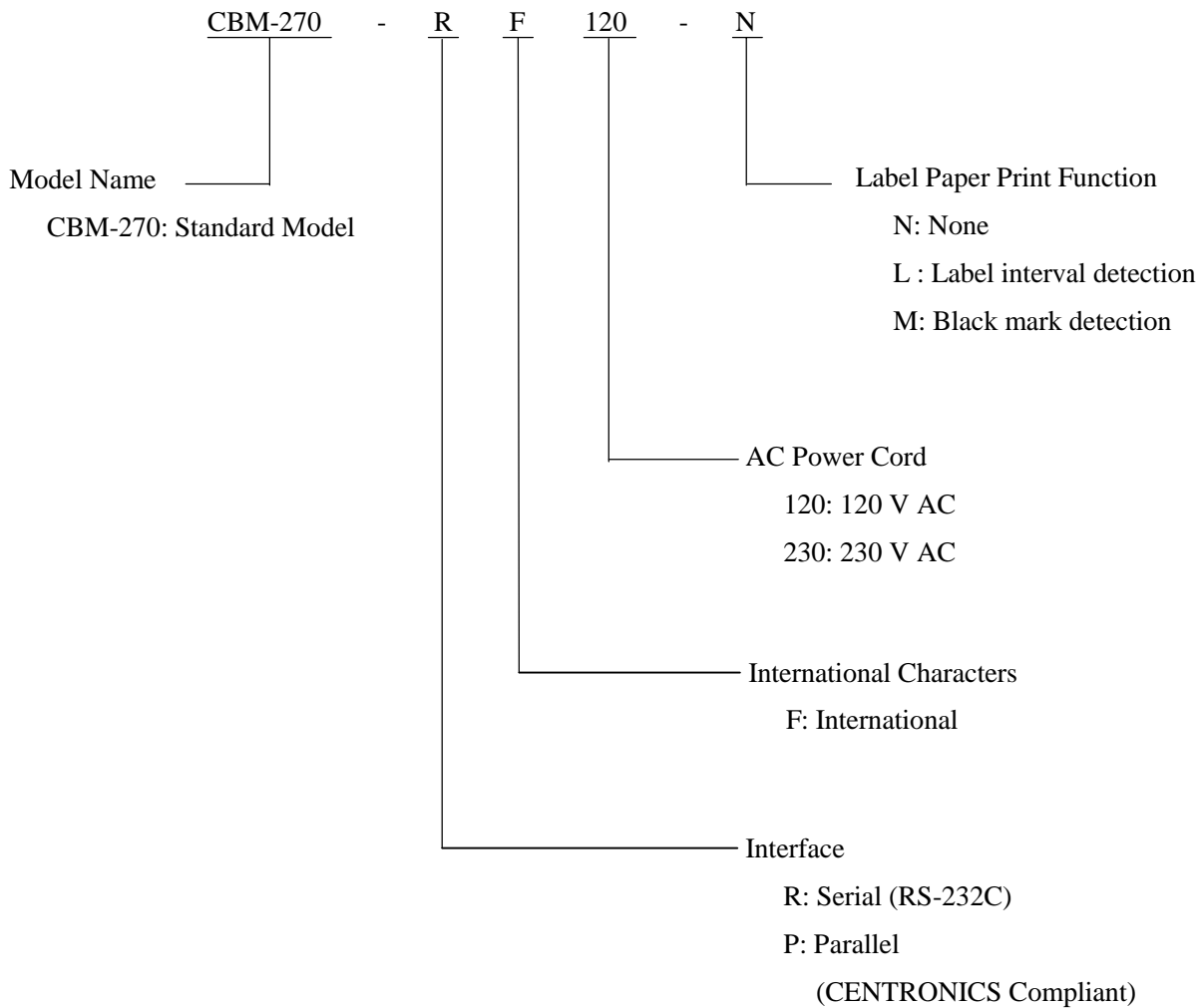

* Special Switching Power Source and Power Cord

Switching power source	: 27AD (Input: 100 to 240V AC)
Power cord	: 100V AC --- 2-core cord 120V AC --- 2-core cord 230V AC --- 2-core cord
Cord length	: Power cord(For AC Input) --- Approx. 1.8 m Secondary side (For DC Output) --- Approx. 1.8 m

2.2 Basic Specifications

Item	Model	CBM-270-RF120- CBM-270-PF120-*	CBM-270-RF230- CBM-270-PF230-*
Printing system		Line thermal dot printing	
Printing width		48 mm (384 dots/line)	
Dot density		8 dots/mm (Width, Length)	
Paper feed pitch		0.125 mm	
Printing speed		Thermal paper: Approx. 11 lines/sec. (At maximum) Label paper: Approx. 7 lines/sec. (At maximum)	
Printing columns and character size		32 columns (12 × 24 Font A) 1.25 × 3.00 mm 42 columns (9 × 24 Font B) 0.88 × 3.00 mm	
Line interval		Initial value: 4.23 mm (1/6 inch) Can be set with a command (1/360 inch at minimum)	
Character types		Alphanumerals, symbols, international characters (Choose from 10 countries)	
Character code		Domestic characters, IBM characters #2 (Choose either)	
Bar code type		UPC-A/E, JAN(EAN) 13-/8-column, ITF, CODE 39, CODE 128, CODABAR	
Paper (See Paper Specifications)		Thermal paper roll : 58 + 0/- 1 mm x ø83 (max.) mm, 60~75µm thick Thermal label paper : 58 + 0/- 1 mm x ø83 (max.), 150µm thick (max.) (L and M Spec. only) Label width: 56 mm (max.) Label length: 25 mm/sh. (min.)	
Interface		Serial (RS-232C), Parallel (CENTRONICS compliant)	
Input buffer		2 KB	
Download characters		Font A, B: 95 characters each	
Auto-loading		Provided (Can be enabled/disabled with the DIP switch)	
Paper end function		Provided	
Paper near end function		Provided (Can be enabled/disabled with the DIP switch)	
Label detecting function		Capable of selecting label interval detection, black mark detection, or none.	
Printing color		Capable of printing in two colors (red/black) with the special thermal paper.	
AC adapter		Rated input : 100 ~ 240 V, 50/60 Hz, 40 VA Rated output : 7.2 V DC, 2 A	
	Type	27 AD	
	AC cord	2-core cord (Depends on the destination)	
Supply voltage		120 V AC +/- 10%, 60 Hz	230 V AC +/- 10%, 50/60 Hz
Power consumption		At non-printing: Approx. 2 W At printing: Approx. 15 W (approx. 20 W at maximum)	
Weight		Main body: Approx. 600 g (Paper roll excluded) AC adapter: Approx. 350 g	
Outer dimensions		106 (W) × 184 (D) × 110 (H) mm	
Operating temperature and humidity		5 ~ 40°C, 35 ~ 85 % RH (No dew condensation)	
Storage temperature and humidity		-20 ~ 60°C, 10 ~ 90% RH (No dew condensation)	
Reliability		Printing head life: (25°C) Pulse resistance : 50 million pulses or more (Print rate 12.5%) Wear resistance : 50 km or more (With recommended thermal paper at normal temperature and humidity)	
EMI	*1	FCC Class-A	EN55022 Class-A
Applicable standard (Main body)	*1		GS, CE Marking
Applicable standard (Power source)		UL, C-UL	GS

* *1 indicates the standard satisfied when the AC adapter 27AD is used.

* GS and CE Marking are satisfied when the main body and AC adapter are combined.

2.3 Paper Specifications

2.3.1 Recommended Paper

- (1) Thermal paper roll
- Type : Thermal paper
 - Paper width : 58 + 0/- 1 mm
 - Paper thickness : 60~75 μ m
 - Roll diameter : ϕ 83 mm or less
 - Printing surface : Outside of the roll (Surface)
 - Recommended paper : TF50KS-E2C (Monochrome) made by NIPPON SEISHI or its equivalent
735FA(2-color, Black based) made by RICOH or its equivalent
PB670(2-color, Red based) made by MITSUBISHI SEISHI or its equivalent
 - Core : ϕ 12 mm (Inner dia.), ϕ 18 mm (Outer dia.)
- (2) Thermal label paper(L and M spec. only)
- Type : Thermal paper (Printing surface)
 - Paper width : 58 + 0/- 1 mm
 - Label width : 56 mm or less
 - Label length : 25~300 mm (For label interval detection)
25~300 mm (For black mark detection) * Black mark section excluded
 - Label interval : 3~300 mm (Black mark interval for the black mark detection)
 - Black mark width : 15 mm or more (From the center of the paper, black paper only)
 - Paper thickness : 150 μ m or less
 - Roll diameter : ϕ 70 mm or less (Depends on the outer diameter of the core)
 - Printing surface : Outside of the roll (Surface)
 - Recommended paper : For label interval detection
KPT86S P22 G63BC (Monochrome) made by OHJI TUCK or its equivalent
For black mark detection
KPT865P (Monochrome) made by OHJI TUCK or its equivalent
 - Core : ϕ 25 mm or more (Outer dia.), 3 mm thick

CAUTION:

1. Use of non-specified paper may cause irregularity of print density. If this is the case, use the DIP switch to reset print density. (See 5. DIP SWITCH SETTING)
2. Do not paste the paper to the core.
3. If the paper comes in contact with a chemical or oil, it may discolor or lose a record.
4. Do not rub the paper surface strongly with a nail or hard metal. It may discolor.
5. Discoloring starts at about 70°C. Watch out for effects of heat, humidity, light, and so on.
6. Do not use the label paper when the printer has been set for thermal paper, and vice versa. Be careful not to mistake a type of label paper. It could cause malfunctioning or damage the printing head.

2.3.2 Printing Position

(1) Thermal paper

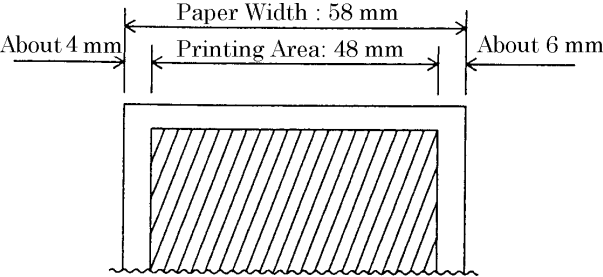

(2) Label paper (For label interval detection) * L spec. only

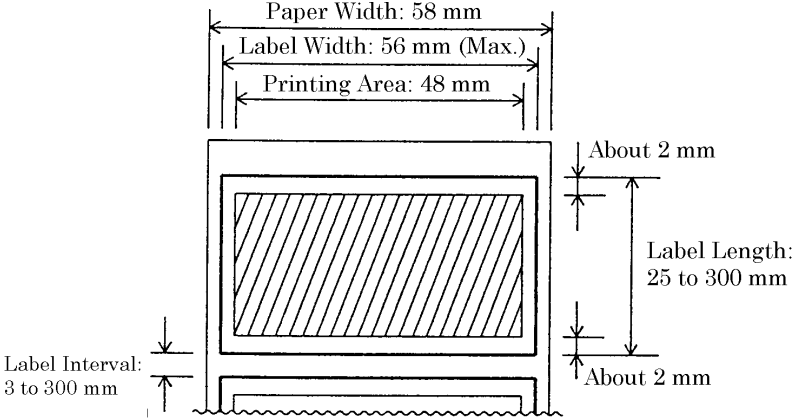

(3) Label paper (For black mark detection) * M spec. only

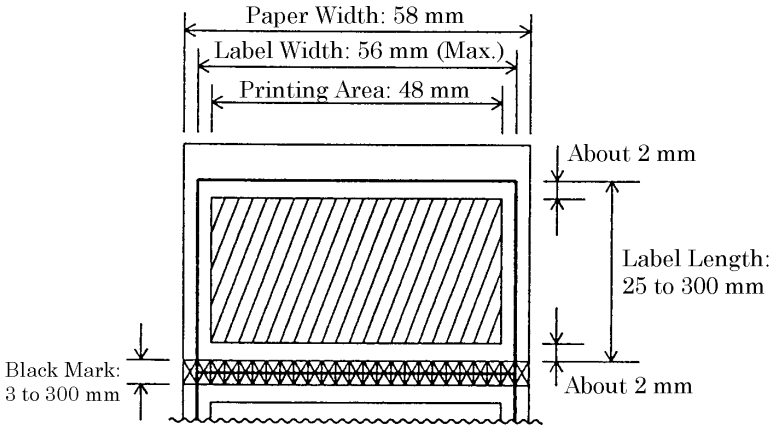

2.3.3 Head and Paper Cutter Layout

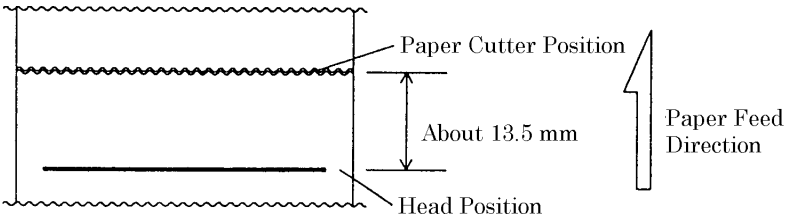

3. OUTER APPEARANCE AND COMPONENT PARTS

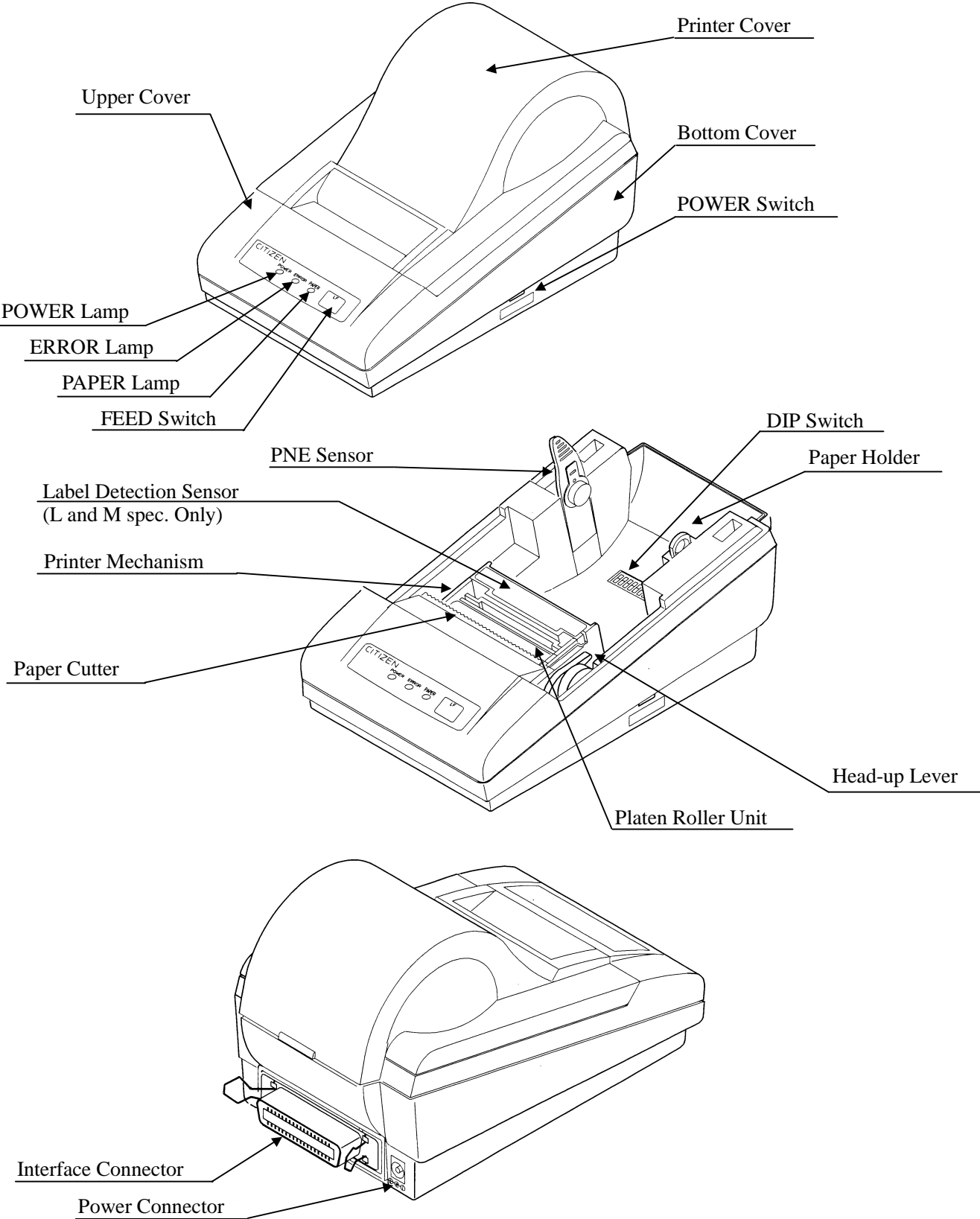

- (1) POWER switch
Turns on/off the power for the printer body.
- (2) POWER lamp
Illuminated when the power switch is turned on.
- (3) ERROR lamp
Illuminated at the time of a head-up mechanical error, and blinks at the time of starting a macro.
- (4) PAPER lamp
Illuminated when the paper is running out (when there is little paper left), and blinks when a label paper cut is specified.
- (5) FEED switch
Feeds the paper. It is fed continuously while the switch is held down. For the label paper, it is fed by one label.
- (6) Paper holder
Set the paper roll in this holder.
- (7) PNE sensor
Detects that the paper is running out.
- (8) DIP switch
Initially sets the printer at power-on and sets the functions.
- (9) Label detection sensor (L and M spec. only)
Detects the labels. Deals with either the label interval or black mark.
- (10) Platen roller unit
Detach this unit when the paper is jamming or when you clean the head.
- (11) Head-up lever
Used when replacing the paper or detaching/reattaching the platen roller unit.
- (12) Paper cutter
Cuts the printed paper.
- (13) Power connector
Connects to the accessory AC adapter (27AD).
- (14) Interface connector
Connects to a communication interface cable. There are two types, for serial and parallel interfaces.
- (15) Printer cover
Detach this cover when replacing the paper.

4. OPERATION

4.1 Connecting AC Adapter

1. Turn off the power.
2. Connect the cable connector of the AC adapter to the power connector located on the back of the printer.
3. Connect the AC power cord of the AC adapter, and plug it into a socket.

CAUTION:

- 1) Use only the specified AC adapter.
- 2) When disconnecting/reconnecting the cable connector of the AC adapter, be sure to hold the connector.
- 3) Separate the AC adapter from other noise-generating devices.
- 4) Pulling the AC power cord may damage it, resulting in a fire, electric shock, or snapping.
- 5) If a thunder/lightning storm is nearby, disconnect the AC adapter from the socket and do not use the printer, because a fire or electric shock may occur.
- 6) Do not put the AC power cord close to a heating device. Its coating can melt and cause a fire or electric shock.
- 7) Install the printer in a well-ventilated place, because the AC adapter generates heat when it is used.
- 8) Use the specified AC power source. Connect to a power source with sufficient capacity. If the capacity is insufficient, a fire may result from heat generation.
- 9) After using the printer or when not using it for a long period of time, be sure to unplug the AC adapter from a plug socket for your safety.

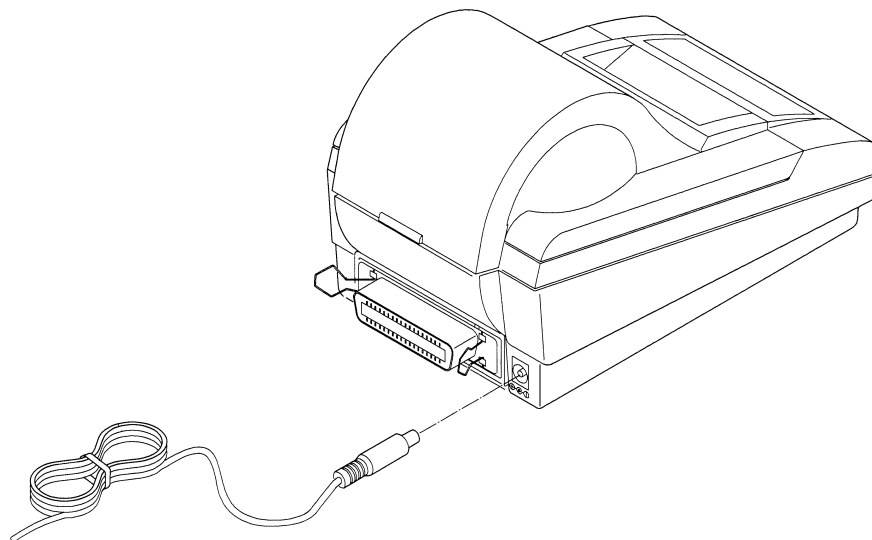

4.2 Connecting Interface Cable

1. Turn off the power. (Mating side included)
2. Check the top and bottom of cable terminals, and connect to the interface connector.
3. Fix the cable terminals. Serial interface : Tighten screws, to fix it.
 Parallel interface : Turn a stopper, to fix it.
4. Connect the cable to the host computer.

CAUTION:

- 1) Referring to "6. PARALLEL INTERFACE" and "7. SERIAL INTERFACE," check the pin configuration of the interface connector and cable. Wrong wiring could cause trouble or malfunctioning to not only the printer body but also the host computer.
- 2) When disconnecting/reconnecting the interface cable, be sure to hold the connector. Pulling the cable itself may snap the internal wires.
- 3) Connect the interface cable securely. Otherwise, communications may not be obtained due to a connection failure.

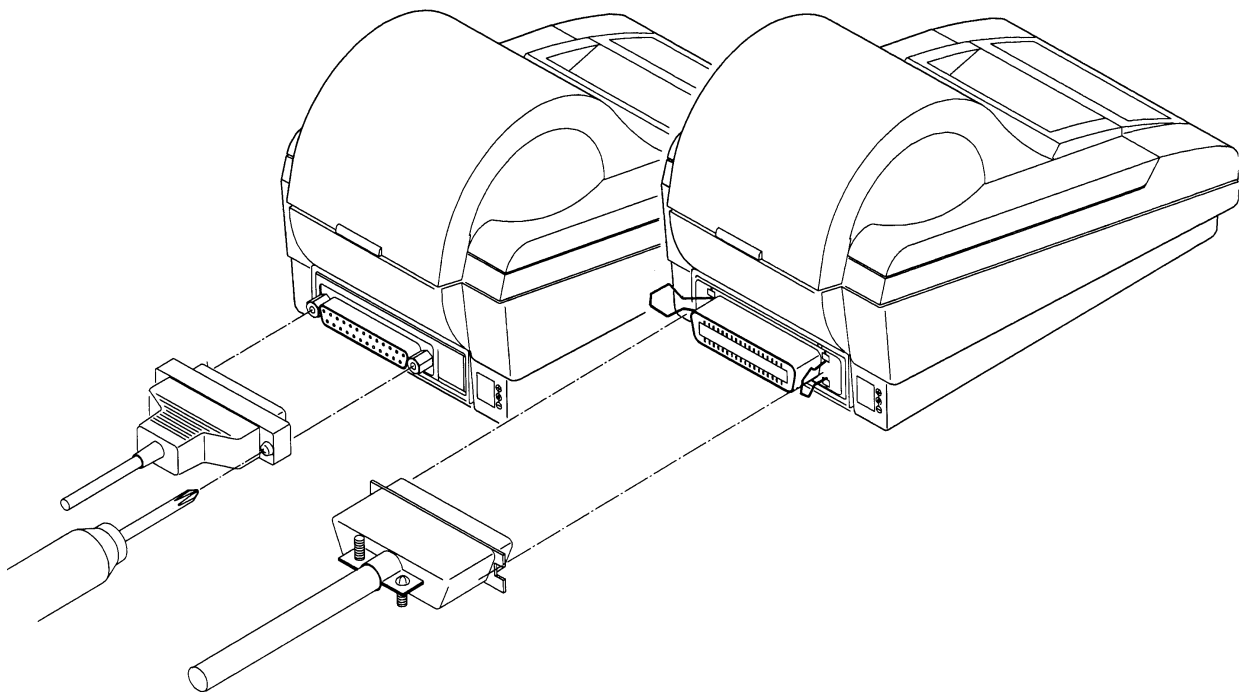

4.3 Inserting the Paper

CAUTION:

- 1) Be sure to use the specified paper roll.
- 2) Use of non-specified paper may not guarantee the print quality, printing head life, and so on.
- 3) Do not use thermal paper when the printer has been set for label paper, and vice versa. It could cause malfunctioning of the printer or damage the printing head.

1. Hold the convexity on the rear of the printer cover, and raise it upward.
2. Cut the front end of the paper roll almost at a right angle.

CAUTION:

- 1) The printer cover is not stationary (Opening/Closing). After detaching it, be careful not to lose or break it.
- 2) Do not insert a ragged or dog-eared end of the paper roll, because it could result in a paper jam or insertion error.

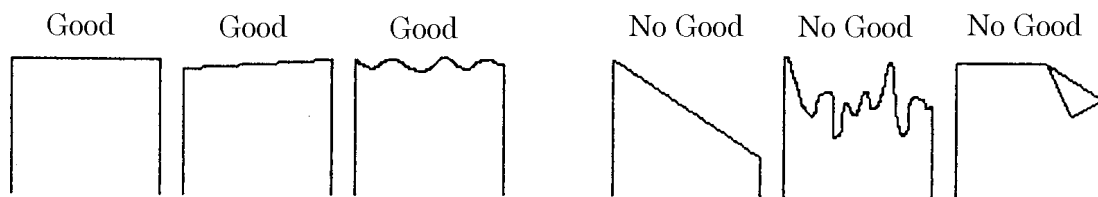

3. Make sure that the power is turned on.
4. Pull the head-up lever to this side to raise up the printing head.
5. If there is still some paper remaining after a paper-out indication, eliminate the paper roll according to "4.4 How to Remove the Remaining Roll Paper."
6. Insert the front end of the paper roll straight into a paper insertion slot.
7. Set the paper roll firmly in the paper holder.
8. Put back the head-up lever. The paper roll is automatically pulled in by the platen roller to feed a constant amount of paper. (When auto-loading is enabled.) (For the label paper, it is fed to the print start position of the 2nd sheet.)
9. Put back the printer cover.

CAUTION:

- 1) If the paper roll is still slack, rewind the paper to remove the slack.
- 2) If the paper roll is tilted, raise the head-up lever to correct the paper roll position, or pull out the paper roll and set it again.
- 3) Do not open the printer cover while printing.
- 4) Do not hold or press the paper roll while printing, because it could cause a paper jam.

- 5) After the paper is set, the printer is made ready to start printing. Note that if data is remaining in the buffer, the printer will start printing after the paper is set.
- 6) Do not run the printer with its cover removed, because it could cause malfunctioning or an irregularity of the sensor.

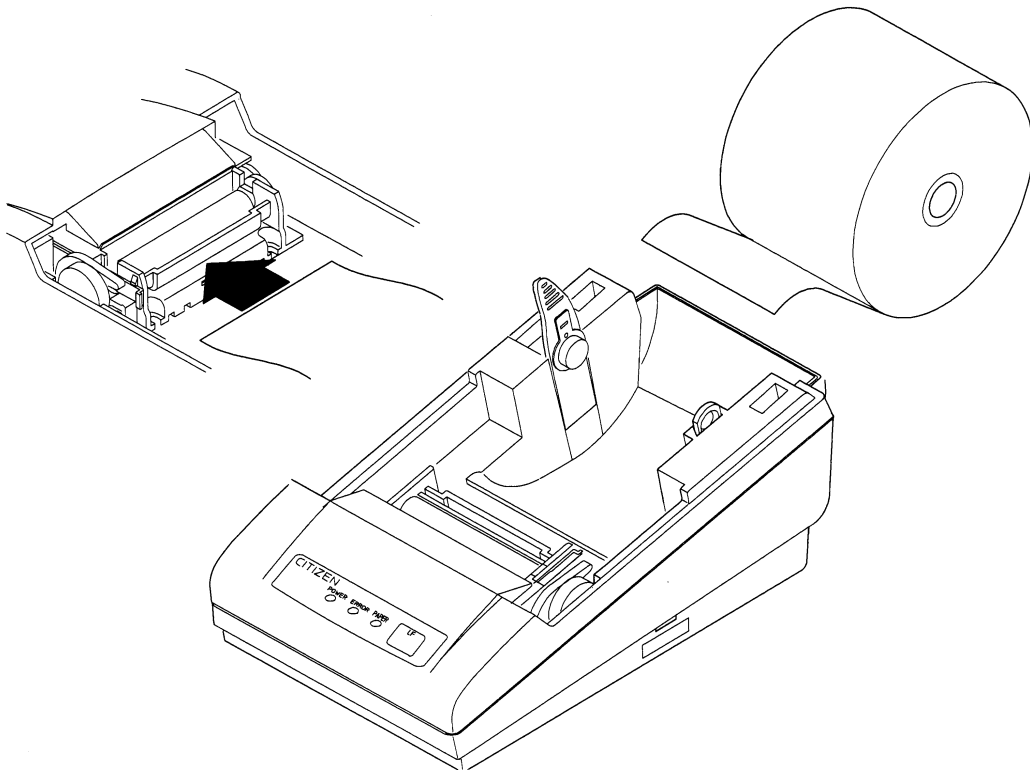

4.4 How to Remove Remaining Paper Roll

1. Remove the printer cover.
2. Raise the head-up lever.
3. Gently pull out the paper to the near side. If the paper roll is still remaining, cut it just before the paper insertion slot before pulling it out.

CAUTION:

- 1) Do not pull out the paper roll in the opposite direction.
- 2) If you do so with the label paper, the labels may come off.
- 3) Never take out paper with the head-up lever lowered, because it could damage the printing head.
- 4) The printer mechanism may be very hot just after printing, so be duly careful.

4.5 Eliminating the Paper Jam

1. Turn off the power.
2. Detach the printer cover.
3. Cut the paper roll near the paper insertion slot.
4. Raise the head-up lever.
5. Raise the blue levers located on both sides of the platen roller unit, to gently detach the unit. The platen roller unit can be detached by manually raising the blue levers.
6. Remove the remaining paper roll completely from the paper passage.
7. If the label paper is used, some paste may be adhered. Dip soft cloth, etc. in alcohol and wipe away the paste carefully so as not to damage the printing head.
8. Confirming the direction of the platen roller unit, reattach it to the mechanism. Shift down the blue levers on both sides, to fix the unit.
9. Lower the head-up lever.

CAUTION:

- 1) Do not carry out this work just after printing because the printing head is very hot.
- 2) Be sure to turn off the power when detaching the platen roller unit.
- 3) When eliminating remaining paper, do not touch the heating surface of the head with a bare hand or metal piece.
- 4) Do not detach the platen roller unit unless necessary, such as for a paper jam.
- 5) When putting back the platen roller unit, be sure to confirm that it is correctly reattached.
- 6) Never detach or reattach the platen roller unit with the head-up lever lowered.

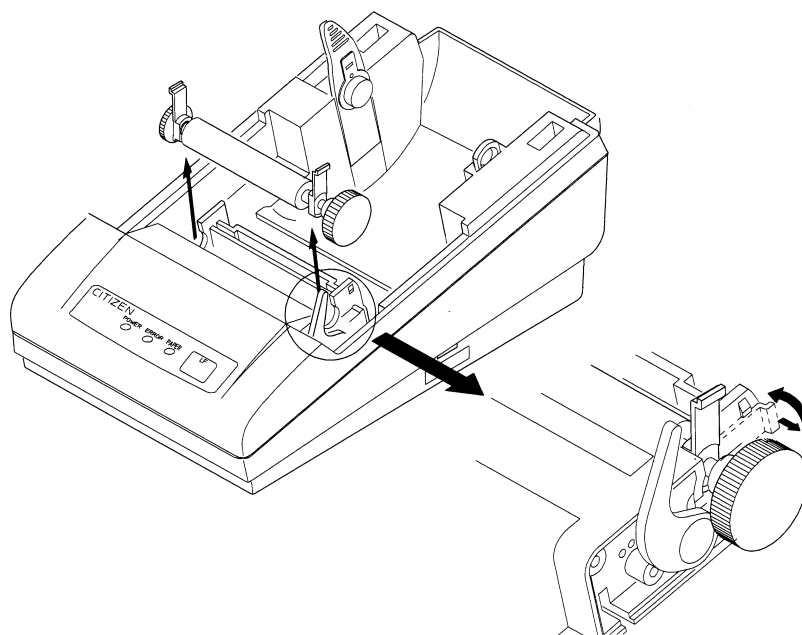

4.6 FEED Switch Function

4.6.1 When Thermal Paper is Used

Pressing the switch, feed the paper by 1 line. If the switch is held down, the paper will be fed continuously.

4.6.2 When Label Paper is Used

Pressing the switch, feed the paper by 1 line. If the switch is held down for 1 second or more, the paper will be fed by one label.

4.6.3 When the Macro is Executed

If the ERROR lamp is blinking while waiting for execution of a macro, press the FEED switch. The waiting state continues until the switch is pressed.

4.6.4 When the Label is Fed to the Paper Cutting Position by the Command

The PAPER lamp blinks. After cutting the paper, pressing the FEED switch searches for the head of the next label. The waiting state continues until the switch is pressed.

CAUTION:

If the label paper is fed by 1 line by pressing the FEED switch, the label head position will be dislocated. Note that if printing starts in this state, the label will be printed dislocated. (It is recommended to feed the paper by 1 label.)

4.7 Paper End Function

If the printing paper runs out, the parallel interface will output BUSY, FAULT, and PE to the host, and the serial interface will output DTR to stop printing, respectively. If some data are still remaining in the buffer, printing will be resumed after replacing the paper. Replace the paper according to "4.3 Inserting the Paper." After replacing the paper, cancel BUSY (DTR), FAULT, and PE outputs. For details, see "4.8 Near Paper End Function."

4.8 Paper Near End Function

If the paper is running out, the PNE sensor informs the host computer that the paper is running out, by means of a signal output or the PAPER lamp on the panel. The PAPER lamp is illuminated unconditionally.

1. If the PNE sensor detects that the paper is running out, the PAPER lamp will be illuminated.
2. If PNE is enabled, the parallel interface will output PE. (At initial setting)
3. Printing is allowed up to about 1.5 m. (Initial value) After printing or feeding the paper by a specified amount, the parallel interface will output BUSY and FAULT, and serial interface will output DTR to stop printing, respectively.
4. Replace the paper according to the procedure in "4.3 Inserting the Paper."
5. After replacing the paper, cancel the BUSY (DTR), FAULT, and PE outputs.

- (1) The following lists the outputs made by the near paper end function and the paper end function. The output state can be changed by the DIP switch or a command.

DS1-1 State	PNE Function	PE Signal Output Setting by Command	PE Output	BUSY (DTR)/ FAULT Output	PAPER Lamp
OFF	Disabled	*When PE is selected	*When PE is detected	*When PE is detected	*At PNE
		When PNE is selected	When PNE is detected	When PE is detected	At PNE
ON	Enabled	When PE is selected	When PE is detected	When printing stops due to PNE	At PNE
		*When PNE is selected	*When PNE is detected	*When printing stops due to PNE	*At PNE

*Mark : Default setting

PNE : Paper Near End PE : Paper End

- (2) Print amount after detecting PNE

When PNE is enabled, a printable amount after PNE detection can be adjusted. PNE is detected when the remaining amount of the paper roll is about 2~3 m. (It depends on the paper quality used, paper thickness, and operating environment.)

An initial value is 1.5 m. Up to 1.5 m can be printed after detecting PNE. At this time, with the approx. 70 μ m-thick recommended paper, the remaining amount of the paper will be about 0.5~1.5 m when printing stops.

It can be adjusted between 0 and 2.55 m with a command. Adjust it depending on the operating environment and paper quality.

Depending on an adjustment value, paper end may be detected (Printing stop) first.

If PNE is detected at power-on, a set amount of printing will be done from that point. (The default is 1.5 m)

4.9 Auto-Loading Function

This printer has a function to automatically set the paper. If the paper end sensor, near paper end sensor, and head-up lever are cancelled, the paper will be automatically fed by a constant amount in about 1 second. (Up to the print start position of the second sheet in the case of label paper.)

In order to smooth operation, cancel the head-up mechanism last.

Also, you can use the DIP switch to enable/disable the function. If disabled, auto-loading will not be performed. (The paper is fed to the print start position in the case of label paper.)

CAUTION:

- 1) When auto-loading is being activated, do not touch the paper roll, because it could result in a paper feed failure or cause the paper to be one-sided.
- 2) Be sure to set the paper until it comes into contact with the platen roller; otherwise, the paper cannot be fed and the printing head could be damaged.
- 3) In the case of label paper, if the label section or black mark (Between the labels) cannot be detected in feeding the paper by a constant amount, the printer will illuminate the ERROR lamp and stop operation, regarding it as a paper error.

4.10 Self-Print Function

This printer has a function to perform preset printing. Turn on the power with the FEED switch held down. It will print the ROM version, DIP switch state, characters used, kanji, etc. After self-printing is completed, the printer restores its normal operating conditions.

In the case of label paper, it is fed to the print start position of the next label.

CAUTION:

- 1) Do not use this function when the paper roll is running out.
- 2) If the label length is short in printing on label paper, printing will extend over several labels.
- 3) Data communication cannot be done during self-printing.
- 4) The print contents differ between thermal paper and label paper.



4.11 Operation Panel and Display of Error

1. POWER lamp (Green)

Illuminated if the power is turned on.

2. ERROR lamp (Red), PAPER lamp (Red)

Indicates an error by illuminating or blinking the lamps.

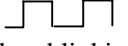
Error	Display		Reset
	ERROR Lamp	PAPER Lamp	
Memory check error	 Quick blinking	OFF	Cannot be reset
Head-up	ON	OFF	Lower the head-up lever.
Head overheat	ON	OFF	Automatically reset by a temperature drop
Paper near end	OFF	ON	Set a new paper roll after a print stop.
Paper end	OFF	ON	Set a new paper roll.
Macro execution wait	 Slow blinking	OFF	Press the FEED switch.
Label paper cut wait	OFF	 Slow blinking	Press the FEED switch.
Label paper error	ON	ON	Set the label paper suitable for the specifications.

<Error Details>

- Head-up ----- Occurs when the head-up lever is raised. The printer cannot feed the paper or print. The parallel interface outputs BUSY and FAULT, and serial interface DTR, respectively.
- Head overheat ----- If the temperature of the printing head rises (About 60°C or more), in order to protect it against overheating, a printing head temperature sensor will be activated to stop printing. The parallel interface outputs BUSY and FAULT, and serial interface DTR, respectively. If the temperature drops (About 55°C), printing will be automatically resumed.
- Paper near end ----- If the diameter of the paper roll decreases, the paper near end sensor will react to inform you that the paper roll is running out. See "4.8 Paper Near End Function".
- Paper end ----- If the paper roll runs out, the paper sensor near the printing head will react to stop printing. See "4.7 Paper End Function".
- Label paper error ----- Occurs if you set the thermal paper or non-specified label paper, when the label paper has been selected. The parallel interface outputs BUSY and FAULT, and serial interface DTR, respectively.

3. FEED switch

See "4.6 FEED Switch Function."

5. DIP SWITCH SETTING

5.1 Location of DIP Switch

1. Turn off the power.
2. Detach the printer cover, and take out the paper roll. (The switch is found under the paper roll.)
3. There are 2 switches (8-pole and 4-pole) for the serial interface, and 1 switch (8-pole) for the parallel interface.

5.2 DIP Switch Function

DS1

No.	Function	ON	OFF	Upon Shipment
1	PNE selection	Enabled	Disabled	ON
2	CR switching	LF operation	Ignored	OFF
3	Print density	See Table 1		ON
4				OFF
5	Paper selection	Label paper	Thermal paper	OFF
6	Auto-loading	Enabled	Disabled	ON
7	DTR/DSR, XON/XOFF	XON/XOFF	DTR/DSR	OFF
8	Kanji code selection	S-JIS	JIS	OFF

* DS1-7: Enabled only for the serial interface. Disabled for the parallel one.

DS2 (For Serial Interface Only)

No.	Function	ON	OFF	Upon Shipment
1	Baud rate and parity setting	See Table 2		OFF
2				OFF
3				OFF
4				OFF

Table 1

	Light	Standard	Slitly Dark	Dark
DS1-3	OFF	ON	OFF	ON
DS1-4	OFF	OFF	ON	ON

Table 2

DS2-4	DS2-3	DS2-2	DS2-1	Parity	Baud Rate
OFF	OFF	OFF	OFF	None	9,600 bps
OFF	OFF	OFF	ON	None	1,200
OFF	OFF	ON	OFF	None	2,400
OFF	OFF	ON	ON	None	4,800
OFF	ON	OFF	OFF	None	9,600
OFF	ON	OFF	ON	None	19,200
OFF	ON	ON	OFF	Odd	1,200
OFF	ON	ON	ON	Odd	2,400
ON	OFF	OFF	OFF	Odd	4,800
ON	OFF	OFF	ON	Odd	9,600
ON	OFF	ON	OFF	Odd	19,200
ON	OFF	ON	ON	Even	1,200
ON	ON	OFF	OFF	Even	2,400
ON	ON	OFF	ON	Even	4,800
ON	ON	ON	OFF	Even	9,600
ON	ON	ON	ON	Even	19,200

5.3 Jumper Wire Function

The jumper wires have been set at shipment. The following lists the basic settings at shipment. Check the settings by performing self-printing.

Jumper Wires

No.	Function	Short	Open	Upon Shipment
J1	International character	See Table 3		Short
J2				Short
J3				Short
J4	Data bit length	7 bits	8 bits	Open
J5	Unused	–	–	Open
J6	Label detection	Black mark	Label interval	Open
J7	Unused	–	–	Open
J8	Communication error mark	Ignored	"?" printed	Open

* J4: Serial interface only. Disabled for the parallel one.

* J5 ~ J7: Do not change the shipment settings.

Table 3

No.	USA	France	Germany	U.K.	Denmark-I	Sweden	Italy	Japan
J1	Short	Open	Short	Open	Short	Open	Short	Open
J2	Short	Short	Open	Open	Short	Short	Open	Open
J3	Short	Short	Short	Short	Open	Open	Open	Open

CAUTION:

- 1) Never change the settings of the jumper wires.
- 2) If you want to change their settings, consult us.
- 3) Never disassemble the printer body. It could cause trouble, etc.

6. PARALLEL INTERFACE

6.1 Specifications

- Data input system : 8-bit parallel (DATA1 to DATA8)
- Control signals : $\overline{\text{ACK}}$, $\overline{\text{BUSY}}$, $\overline{\text{STROBE}}$, $\overline{\text{FAULT}}$, $\overline{\text{PE}}$, $\overline{\text{RESET}}$
- Applicable connectors : Printer side : 57LE-40360 (Anphenol) or its equivalent
Cable side : 57-30360 (Anphenol) or its equivalent

6.2 Connector's Pin Configuration

No.	Signal Name	No.	Signal Name
1	$\overline{\text{STROBE}}$	19	TWISTED PAIR GND
2	DATA 1	20	↑
3	DATA 2	21	↑
4	DATA 3	22	↑
5	DATA 4	23	↑
6	DATA 5	24	↑
7	DATA 6	25	↑
8	DATA 7	26	↑
9	DATA 8	27	↑
10	$\overline{\text{ACK}}$	28	↑
11	$\overline{\text{BUSY}}$	29	↑
12	$\overline{\text{PE}}$	30	↑
13	+ 5V DC	31	$\overline{\text{RESET}}$
14		32	$\overline{\text{FAULT}}$
15		33	GND
16	GND	34	
17	FRAME GND	35	
18		36	

6.3 Input and Output Signals

6.3.1 Input and Output Signals

(1) Input signals to the printer

- DATA : 8-bit parallel signal (Positive logic)
- $\overline{\text{STROBE}}$: Strobe signal to read the 8-bit data (Negative logic)
- $\overline{\text{RESET}}$: Signal to reset the entire printer (Negative logic); 1 ms or more

- (2) Output signals from the printer
- $\overline{\text{ACK}}$: 8-bit data request signal. A pulse signal to be output at the end of the BUSY signal (Negative logic)
 - BUSY : Signal to indicate that the printer is busy. Input new data when it is "Low." (Positive logic)
 - $\overline{\text{FAULT}}$: Turned to "Low" when the printer has an alarm. At this time, all the control circuits in the printer stop. (Negative logic)
 - PE : Output if the printing paper has run out or is running out. (Positive logic)
- (3) Power source and the related
- +5 V DC : 5 V output pulled up by a 10k Ω resistor
 - GND : Common ground for the circuits

6.3.2 Electrical Characteristics

- (1) Input signal level
 All the input signals are at the TTL level.
 High level --- 2.0 V at minimum
 Low level --- 0.8 V at maximum
- (2) Output signal level
 All the output signals are at the TTL level.
 High level --- 2.4 V at minimum
 Low level --- 0.4 V at maximum
- (3) Input and output conditions
 The $\overline{\text{STROBE}}$ and $\overline{\text{RESET}}$ input signals are pulled up at 10k Ω , and the other input signals at 50k Ω , respectively.

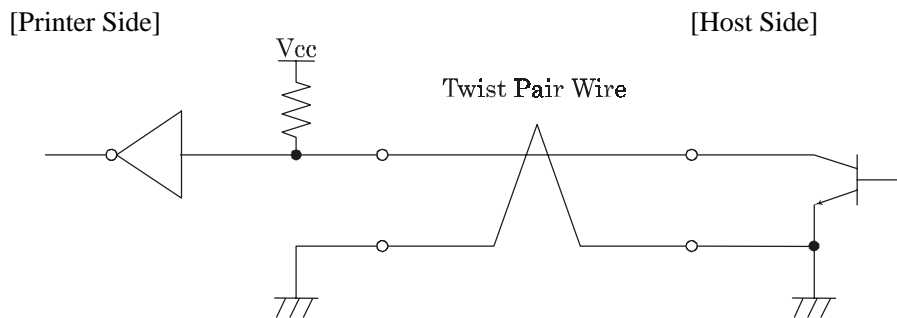

All the output signals are pulled up at 50k Ω .

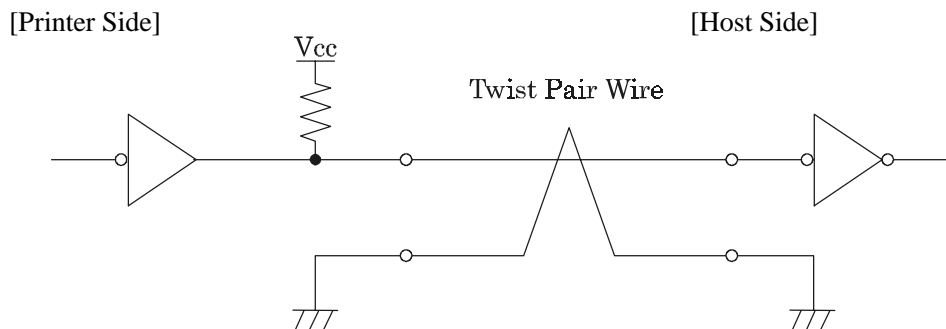

6.3.3 Timing Chart

Data Input and Print Timings

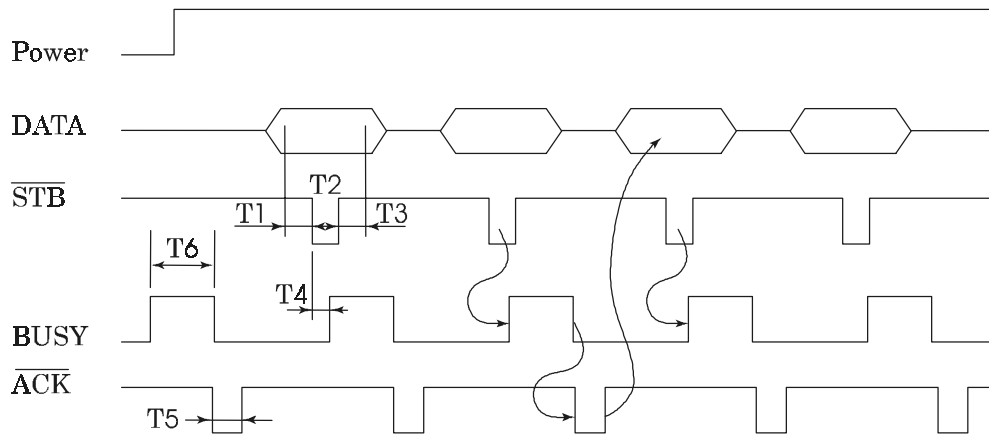

T_1, T_2, T_3	0.5 μ s MIN
T_4	270 ns MAX
T_5	2.3 μ s TYP
T_6	500 ms MIN (At power-on)

6.3.4 Data Receiving Control

The data can be received from the host when the BUSY signal is at "Low," but cannot be received when it is "High."

6.3.5 Buffering

The host side is immediately freed, because 2 KB data can be buffered.

7. SERIAL INTERFACE

7.1 Specifications

- (1) Synchronous system : Asynchronous
- (2) Baud rate : 1,200, 2,400, 4,800, 9,600, 19,200 bps (Selected by the user)
- (3) 1-word configuration
 - Start bits : 1 bit
 - Data bits : 8 bits or 7 bits (Setting upon shipment)
 - Parity bits : Odd, even, or no parity (Selected by the user)
 - Stop bits : 1 bit or more
- (4) Signal polarity
 - RS-232C
 - Mark = Logic "1" (-3 ~ -12 V)
 - Space = Logic "0" (+3 ~ +12 V)
- (5) Received data (RXD signal)
 - Mark = 1
 - Space = 0
- (6) Reception control (DTR signal)
 - Mark : Data not transferable
 - Space : Data transferable
- (7) Transmission control (TXD signal)
 - DC1 code(11H) X-ON : Data receivable
 - DC3 code(13H) X-OFF : Data not receivable

7.2 Connector's Pin Configuration

No.	Signal Name	Input/Output	Function
1	FG		Frame Ground
7	GND		Signal Ground
3	RXD	Input	Received Data
20	DTR	Output	Printer BUSY Signal
2	TXD	Output	Transmitted Data
6	DSR	Input	Data Set Ready

- [Note] 1. The RS-232C signals are based on the EIA RS-232C.
 2. The received data should be always maintained in the Mark status when no data is being transferred.

Applicable connectors (D-Sub connectors)

- Printer side : 17LE-13250 (Anphenol) or its equivalent
- Cable side : 17JE-23250 (Anphenol) or its equivalent

7.3 Input and Output Signals

7.3.1 Input and Output Signals

(1) RXD

Serial received data signal. If a framing error, overrun error, or parity error takes place, the relevant data will be printed as "?".

(2) DTR

Write the data or a command when this signal is Ready. If you write at Busy, the previous data will be ignored, resulting in an overrun error. The data can be written in the input buffer even during printing. Busy is also issued at power-on, during test printing, at on-line, or at reset.

(3) TXD

If the remaining capacity of the input buffer comes to 128 bytes or less while receiving the data, DC3(13H) will be output as a data not receivable signal. If the remaining capacity comes to 256 bytes or more, DC1(11H) will be output to the host side as a data receivable signal.

When sending the status information, it is confirmed that DSR is a space prior to sending the data, if DTR/DSR control has been selected. If DTR/DSR control has not been selected, the data will be sent, ignoring the DSR signal.

(4) FG

Ground for the case

(5) GND

Common ground for the circuits

7.3.2 Data Configuration

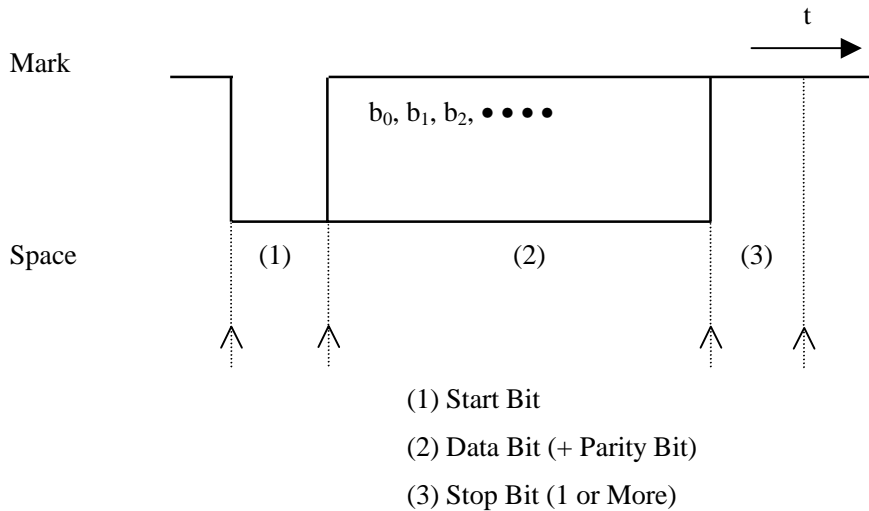

(1) Start bit

The system reads the status again after a lapse of 1/2 bit from a fall edge from the mark to space, and if it is a space, this bit will be recognized as the start bit.

If it is a mark, the system will not recognize the bit as the start bit and try to detect the start bit again without judging it as an error.

(2) Data bits + Parity bit

The system samples the data bits and parity bit for the 1 bit worth of time from 1/2 start bit and assumes the then status as the data for the relevant bits. The bits are called Bit 0, Bit 1, ..., Parity bit, counting from the one closest to the start bit.

(3) Stop bit

The stop bit is the Mark level of 1 bit or more. If a space is detected in detecting the stop bit, a framing error will result.

7.3.3 Error Detection

The system detects a parity, framing, or overrun error. If an error is detected, the relevant data will be stored in the buffer as "?".

(1) Parity error

With a parity check specified, if an error is detected at parity check time, the relevant data will be stored in the buffer as "?".

(2) Framing error

This error results if the Space status is detected at stop bit detection time. The relevant data will be stored in the buffer as "?".

(3) Overrun error

If an overrun error is detected, the relevant data will be stored in the buffer as "?".

7.3.4 Data Receiving Control

If DTR/DSR control has been selected, the data from the host side will be received when the BUSY signal is at "Low," but not received when at "High." If DTR/DSR has not been selected, the data from the host side will be received after sending XON, but not after sending XOFF.

7.3.5 Buffering

To transfer the data to the input buffer, there are two control signals available: DTR signal and TXD signal. The host side is immediately freed, since the data can be buffered up to 2 KB.

- (1) DTR signal (See 7.3.1-(2))
- (2) TXD signal (See 7.3.1-(3))

7.3.6 Electrical Characteristics

RS-232C Circuit

Input (RXD, DSR)

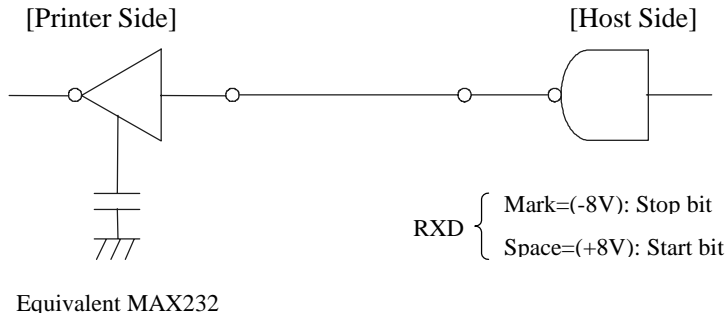

Output (TXD, DTR)

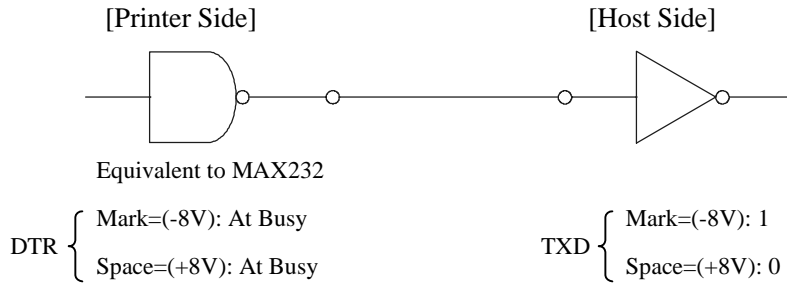

8. POWER CONNECTOR

This connector is to supply the power from the special AC adapter(27AD).

Connector Schematic

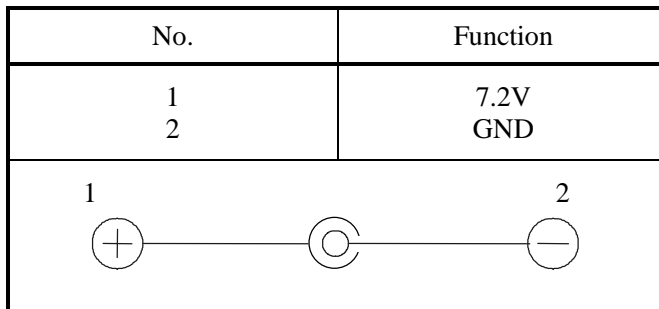

Inner terminal : Minus pole (GND)

Outer terminal : Plus pole

Jack used : HEC0470-01-640 (HOSHIDEN) or its equivalent

Applicable plug : JXP series type A (I.D.: 2.45 mm, O.D.: 5.5 mm) (HOSHIDEN) or its equivalent

CAUTION:

- 1) Be sure to use the specified AC adapter. Use of any other power source could cause trouble to or break the printer.
- 2) Do not connect the power source with different polarity.
- 3) After using the printer or when not using it for a long period of time, be sure to unplug the AC adapter from a plug socket for your safety.

9. MAINTENANCE AND SERVICE

For the information on maintenance and service, please contact our dealer.

10. PRINT CONTROL FUNCTIONS

10.1 Command List

	Command	Function	Code	Page
1	HT	Horizontal tab	09H	32
2	LF	Printing and paper feed	0AH	33
3	CR	Print	0DH	34
4	ESC SP	Setting the right spacing of the character	1BH 20H n	34
5	ESC !	Collective Specifying the printing mode	1BH 21H n	35
6	ESC %	Specifying/Canceling download character set	1BH 25H n	36
7	ESC &	Defining download characters	1BH 26H s n m [a p1 p2...psxa] m-n+1	37
8	ESC *	Specifying the bit image mode	1BH 2AH m n1 n2 [d]k	38
9	ESC -	Specifying/Canceling underline	1BH 2DH n	40
10	ESC 2	Specifying 1/6-inch line feed rate	1BH 32H	40
11	ESC 3	Setting line feed rate of minimum pitch	1BH 33H n	41
12	ESC =	Data input control	1BH 3DH n	42
13	ESC @	Initializing the printer	1BH 40H	41
14	ESC D	Setting horizontal tab position	1BH 44H [n]k 00H	42
15	ESC E	Specifying/Canceling highlighting	1BH 45H n	42
16	ESC G	Specifying/Canceling double printing	1BH 47H n	43
17	ESC J	Printing and feeding paper n/203 inch	1BH 4AH n	44
18	ESC R	Selecting the international character set	1BH 52H n	45
19	ESC V	Specifying/Canceling 90°-right- turned characters	1BH 56H n	46
20	ESC a	Aligning the characters	1BH 61H n	47
21	ESC c 3	Selecting the paper near end sensor valid for a paper end signal output	1BH 63H 33H n	48
22	ESC c 4	Selecting the paper near end sensor valid for print stop	1BH 63H 44H n	48
23	ESC c 5	Enabling/Disabling the panel switches	1BH 63H 45H n	49
24	ESC d	Printing and feeding the paper by n lines.	1BH 64H n	49
25	ESC i	NOP		
26	ESC m	NOP		
27	ESC n	Setting a remaining amount of printout	1BH 6EH n	50
28	ESC t	Selecting the character codes table	1BH 74H n	50
29	ESC v	Transmitting the printer status	1BH 76H n	51
30	ESC {	Specifying/Canceling the inverted characters	1BH 7BH n	52
31	ESC \$	Specifying the absolute positions	1BH 24H n1 n2	53
32	ESC ¥	Specifying the relative positions	1BH 5CH n1 n2	54

	Command	Function	Code	Page
33	GS k	Printing the bar code	1DH 6BH n ['d'] k 00H	55
34	GS w	Specifying the horizontal size(Scale factor) of bar code	1DH 77H n	59
35	GS h	Specifying the height of the bar code	1DH 68H n	59
36	GS H	Selecting the print position of HRI code	1DH 48H n	60
37	GS f	Selecting the font of HRI code	1DH 66H n	61
38	GS *	Defining the download, bit image	1DH 2AH n1 n2 [d] n1 x n2 x 8	62
39	GS /	Printing the download, bit image	1DH 2FH m	63
40	GS :	Starting/Ending macro definition	1DH 3AH	64
41	GS ^	Executing the macro	1DH 5EH n1 n2 n3	65
42	DC2 A	Selecting the printing speed	1DH 41H n	66
43	DC3	Switching the Red/Black printing	13H n	66
44	FF	Printing and Paper feeding to the top of the label	0CH	67
45	GS FF	Printing and discharging the labels (Cutting included)	1DH 0CH	67
46	GS C0	Setting the numbering print mode	1DH 43H 30H m n	68
47	GS C1	Setting the numbering counter mode (A)	1DH 43H 31H n1 n2 n3 n4 n5 n6	69
48	GS C2	Setting the numbering counter	1DH 43H 32H n1 n2	70
49	GS C ;	Setting the numbering counter mode (B)	1DH 43H 3BH N1 3BH N2 3BH N3 3BH N4 3BH N5 3BH	70
50	GS c	Printing the counter	1DH 63H	71
51	GS <	Initializing the printer mechanism	1DH 3CH	72
52	GS A	Correcting the label top position	1DH 41H m n	72

Note) n, n1, n2, n3, n4, n5, n6, m, a, s, p, d, N1, N2, N3, N4, and N5 in the table are parameters for each command.

Note) []k in the table denotes k-times of repeat.

10.2 Command Details

10.2.1 Descriptions of Each Item

XXXXXX

[Function]	Command Function
[Code]	A sequence of code constituting a command is represented in hexadecimal number for < >H, binary number for < >B, and decimal number for < >, respectively; []k represents a repeat count of k-times.
[Range]	Describes an argument value(Setting range) for the command.
[Outline]	Describes a command outline.
[Caution]	Describes a caution as required.
[Default]	Describes an initial value for the command when accompanied by an argument.
[See Also]	Describes the associated commands for use.
[Sample Program]	Describes a coding example in the Q-BASIC sample program. * This example is only for your reference and differs depending on the language used, version, and so on. For details, see the manual for the language used.
[Print Result]	Shows a print result obtained by running the above-mentioned program. However, the print result shown here has a different scale from the actual print result.
XXXX	Represents the command.

10.2.2 Command Details

HT

[Function] Horizontal tab

[Code] <09> H

[Outline] Shifts the printing position to the next horizontal tab position.
 • Ignored when the next horizontal tab position has not been set.

[Caution] • The horizontal tab position is set by ESC D.
 • Initial setting of the horizontal tab position is each 8 characters in 9th, 17th, 25th, 33rd, columns.

[See Also] ESC D

[Sample Program]

```
LPRINT "0123456789012345678901" ;
LPRINT CHR$ (&HA) ;
LPRINT CHR$ (&H9) ; "AAA" ;
LPRINT CHR$ (&H9) ; "BBB" ;
LPRINT CHR$ (&HA) ;
LPRINT CHR$ (&H1B) ; "D" ;
LPRINT CHR$ (3) ; CHR$ (7) ; CHR$ (14) ; CHR$ (0) ;
LPRINT CHR$ (&H9) ; "AAA" ;
LPRINT CHR$ (&H9) ; "BBB" ;
LPRINT CHR$ (&H9) ; "CCC" ; CHR$ (&HA) ;
END
```

[Print Results]

```
012345678901234567890 1
      AAA      BBB ← Initially set horizontal tab
    AAA BBB   CCC ← When set to the 4th, 8th, and 15th digits
```

LF

[Function] Printing and Paper Feed

[Code] <0A>H

[Outline] Prints data inside the input buffer and feeds lines based on the line feed amount having been set.

- The head of the line becomes the next print starting position.

[See Also] ESC 2, ESC 3

[Sample Program]

```
LPRINT "AAA" ; CHR$ (&HA) ;  
LPRINT "BBB" ; CHR$ (&HA) ;  
LPRINT CHR$ (&HA) ;  
LPRINT "CCC" ; CHR$ (&HA) ;  
END
```

[Print Results]

```
AAA      ← Print and line feed  
BBB      ← Print and line feed  
         ← Line feed only  
CCC      ← Print and line feed
```

CR

- [Function] Print
- [Code] <0D>H
- [Outline] 1) When DS1-2 is OFF:
 This command is ignored.
- 2) When DS1-2 is ON:
 With data held inside the internal print buffer, printing and line feed are performed.
 Without data inside the internal print buffer, however, no printing is performed.

[See Also] LF

[Sample Program]

```
LPRINT "AAA" ; CHR$ (&HD) ;
LPRINT "BBB" ; CHR$ (&HD) ;
LPRINT CHR$ (&HD) ;
LPRINT "CCC" ; CHR$ (&HD) ;
END
```

[Print Results]

When DS1-2 is OFF

When DS1-2 is ON

```
AAA            ← Print and line feed
BBB            ← Print and line feed
                 ← Line feed only
CCC            ← Print and line feed
```

ESC SP n

- [Function] Setting the right spacing of the character
- [Code] <1B> H <20> H <n>
- [Range] $0 \leq n \leq 32$
- [Outline] The rightward space amount is set in dot unit (1/203 inch unit). In the initial value, it is n=0.
- [Caution] The rightward space amount in double wide mode is made double of the set volume.
- [Default] n = 0

[Sample Program]

```
LPRINT CHR$ (&H1B) ; " " ; CHR$ (0) ;
LPRINT "AAAAA" ; CHR$ (&HA) ;
LPRINT CHR$ (&H1B) ; " " ; CHR$ (1) ;
LPRINT "AAAAA" ; CHR$ (&HA) ;
LPRINT CHR$ (&H1B) ; " " ; CHR$ (12) ;
LPRINT "AAAAA" ; CHR$ (&HA) ;
END
```

[Print Results]

```
AAAAA    ← 0-dot space
A A A A A   ← 1-dot space
A A A A A   ← 12-dot space
```

ESC ! n

[Function] Collective specifying the printing mode

[Code] <1B> H <21> H <n>

[Range] $0 \leq n \leq 255$

[Outline] Printing mode is assigned. Each n bit indicates the following:

Bit	Function	Value	
		0	1
0	Character Font	Font A	Font B
1	Undefined		
2	Undefined		
3	High-lighting	Canceled	Specified
4	Double height	Canceled	Specified
5	Double width	Canceled	Specified
6	Undefined		
7	Underline	Canceled	Specified

- [Caution]
- With double height and double width being specified simultaneously, double wide and double high characters are consisted.
 - An underline is attached to the full character width, which, however, is not attached to the part having been skipped by the horizontal tab. Neither is it attached to 90°-right-turned characters.
 - The underline width is as having been specified by <ESC - >. (The default setting is 1 dot width.)
 - Specification with this command is invalid to Kanji, except specification and cancellation of highlighting
 - In case that double wide character and normal character exist in same one line, the layout of underline is consistent one.

[Default] n = 0

[See Also] ESC E, ESC -

[Sample Program]

```
LPRINT CHR$ (&H1B) ; " ! " ; CHR$ (&H00) ; "H" ;
LPRINT CHR$ (&H1B) ; " ! " ; CHR$ (&H01) ; "H";
LPRINT CHR$ (&H1B) ; " ! " ; CHR$ (&H08) ; "H";
LPRINT CHR$ (&H1B) ; " ! " ; CHR$ (&H10) ; "H";
LPRINT CHR$ (&H1B) ; " ! " ; CHR$ (&H20) ; "H";
LPRINT CHR$ (&H1B) ; " ! " ; CHR$ (&H80) ; "H";
LPRINT CHR$ (&H1B) ; " ! " ; CHR$ (&HB9) ; "H";
LPRINT CHR$ (&HA) ;
END
```

[Print Results]

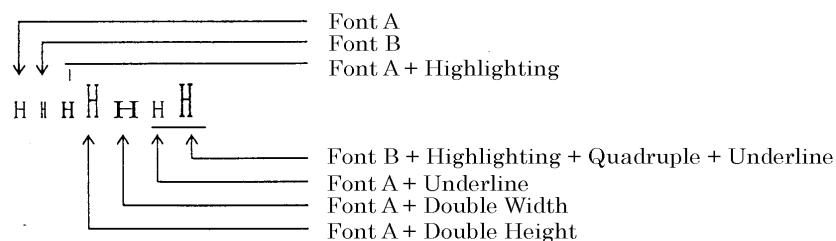

ESC % n

[Function] Specifying/Canceling download character set

[Code] <1B> H <25> H <n>

[Range] $0 \leq n \leq 255$

[Outline] Specifying/canceling download characters.
Further, only the lowest bit (n0) is valid for n.

The lowest bit (n0) indicates the following.

n0	Function
0	Canceling download character set
1	Specifying download character set

[Caution] Download characters and download bit images can not be defined simultaneously.

[Default] $n = 0$

[See Also] ESC &

[Sample Program]

```

GOSUB *SETCHR                                DATA 6
LPRINT CHR$ (&H1B); "%"; CHR$ (0);          DATA &HFF, &H80, &H00
LPRINT "@A"; CHR$ (&HA);                    DATA &H80, &H80, &H00
LPRINT CHR$ (&H1B); "%"; CHR$ (1);          DATA &H80, &H80, &H00
LPRINT "@A"; CHR$ (&HA);                    DATA &H80, &H80, &H00
END                                            DATA &HFF, &HFF, &HFF
  *SETCHR :                                    DATA &HFF, &HFF, &HFF
LPRINT CHR$ (&H1B); "&";                    DATA 12
LPRINT CHR$ (3); "@"; "A";                  DATA &HFF, &HFF, &HFF
FOR J=1 TO 2                                  DATA &H80, &H07, &HF9
  READ REP                                    DATA &H80, &HFF, &HF9
  LPRINT CHR$ (REP);                          DATA &H87, &HFE, &H01
  FOR I=1 TO REP*3                             DATA &H9F, &H06, &H01
    READ D                                     DATA &HF8, &H06, &H01
    LPRINT CHR$ (D);                          DATA &HF8, &H06, &H01
  NEXT I                                       DATA &H9F, &H06, &H01
NEXT J                                         DATA &H87, &HFE, &H01
RETURN                                        DATA &H80, &HFF, &HF9
                                                DATA &H80, &H07, &HF9
                                                DATA &HFF, &HFF, &HFF
    
```

[Print Results]

@ A ← Internal Character Set

☐ ☒ ← Download Character

ESC & s n m [a [p] s×a] m-n+1

- [Function] Defining the download characters
- [Code] <1B> H <26> H <s> <n> <m> [<a> <p1> <p2> ... <ps×a>] m-n+1
- [Range]
 - s = 3
 - 32 ≤ n ≤ m ≤ 126
 - 0 ≤ a ≤ 12 (Font A)
 - 0 ≤ a ≤ 9 (Font B)
 - 0 ≤ p1 ... ps×a ≤ 255
- [Outline] Defines the font of download characters of alphanumeric characters.
 - "s" indicates the number of bytes in vertical direction.
 - "n" indicates the start character code and m the end character code. To define only one character, set n=m.
 - Character codes definable includes 95 ASCII codes in total between 32~126.
 - "a" indicates the number of dots in horizontal direction for definition.
 - "p" is the data to be defined, which indicate a pattern equal to "a" dot in horizontal direction from the left end. The rest of the pattern on the right side is filled with space.
 - The rest of data to be defined is s x a.
 - Download characters thus defined remain valid until redefinition, ESC @ execution, GS * execution, or power OFF is practiced.
- [Caution] Download characters and download bit images can not be defined simultaneously.
Running this command clears the definition of the download bit image.
- [Default] Same as the internal character set
- [Example]

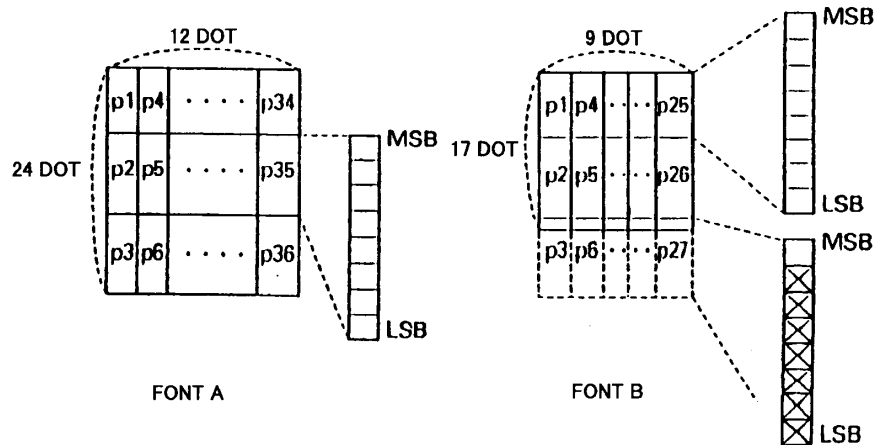

Create each data bit by setting "1" for a printed dot and "0" for an unprinted dot.

- [Sample Program] [Print Results]
- See Sample Program and Print Results for ESC % on Page 36.

ESC * m n1 n2 [d] k

[Function] Specifying the bit image mode
 [Code] <1B> H <2A> H <m> <n1> <n2> [<d>] k
 [Range] m= 0, 1, 32, 33
 $0 \leq n1 \leq 255$
 $0 \leq n2 \leq 1$
 $0 \leq d \leq 255$
 $k = n1 + 256 \times n2$ (m = 0, 1)
 $k = (n1 + 256 \times n2) \times 3$ (m = 32, 33)

- [Outline] According to the number of dots specified in n1, n2, specify the bit image of mode n.
- The No. of dots printed is divided by 256, whose quotient is taken as n2 and residual as n1.
 - The total no. of dots printed in the bit image is equal to $n1 + (256 \times n2)$.
 - When bit image data have been input in excess of dot position of one line (448 dots), the excess data are discarded.
 - d is bit image data, the bits subject to printing are taken as "1" and those not as "0".
 - The bit image modes specified by m are shown as follows:

m	Mode	Vertical Direction		Horizontal Direction	
		No. of Dots	Dot Density	Dot Density	Max. No. of Dots
0	8-dot single density	8	67 DPI	101 DPI	192
1	8-dot double density	8	67 DPI	203 DPI	384
32	24-dots single density	24	203 DPI	101 DPI	192
33	24-dots double density	24	203 DPI	203 DPI	384

- [Caution]
- When the values set in m (Bit image mode) are out of the above range, the data following after n1 is processed as normal printing data.
 - After completion of bit image printing, printer returns to normal data processing mode.

[Example]

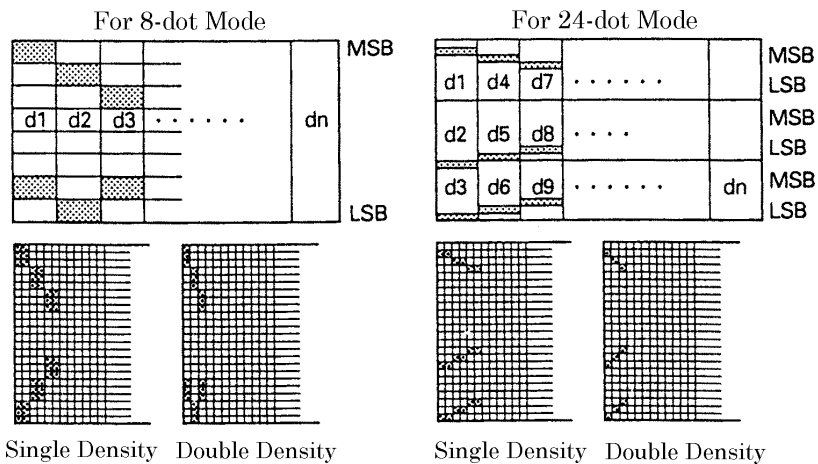

[Sample Program]

```

LPRINT CHR$ (&H1B) ; "*" ;
LPRINT CHR$ (0) ; CHR$ (20) ; CHR$ (0) ;
GOSUB *IMG1
LPRINT CHR$ (&HA) ;
LPRINT CHR$ (&H1B) ; "*" ;
LPRINT CHR$ (1) ; CHR$ (20) ; CHR$ (0) ;
GOSUB *IMG1
LPRINT CHR$ (&HA) ;
LPRINT CHR$ (&H1B) ; "*" ;
LPRINT CHR$ (32) ; CHR$ (20) ; CHR$ (0) ;
GOSUB *IMG2
LPRINT CHR$ (&HA) ;
LPRINT CHR$ (&H1B) ; "*" ;
LPRINT CHR$ (33) ; CHR$ (20) ; CHR$ (0) ;
GOSUB *IMG2
LPRINT CHR$ (&HA) ;
END

*IMG1:
LPRINT CHR$ (&HFF) ;
FOR I=1 TO 18
    LPRINTCHR$ (&H85) ;
NEXT I
LPRINT CHR$ (&HFF) ;
RETURN

*IMG2 :
FOR I=1 TO 3
    LPRINT CHR$ (&HFF) ;
NEXT I
FOR I=1 TO 18
    LPRINTCHR$ (&H80) ;
    LPRINTCHR$ (&H00) ;
    LPRINTCHR$ (&H05) ;
NEXT I
FOR I=1 TO 3
    LPRINT CHR$ (&HFF) ;
NEXT I
RETURN
    
```

[Print Results]

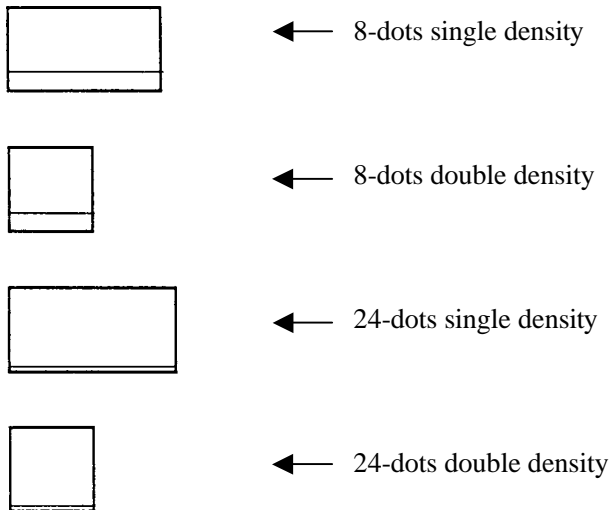

ESC – n

[Function] Specifying/Canceling underline

[Code] <1B> H <2D> H <n>

[Range] $0 \leq n \leq 2$

[Outline] Specifying/canceling an underline.

- Types of underlines by n value are shown below:

n	Type
0	Canceling an underline.
1	Specifying an underline for 1-dot width
2	Specifying an underline for 2-dots width

- [Caution]
- An underline is attached to the full character width. It is, however, not attached to the part having been skipped by horizontal tab command.
 - An underline is not attached to a 90 °- right-turned characters.
 - Specification/cancellation with this command is invalid to Kanji.

[See Also] ESC !, FS –

[Sample Program]

```
LPRINT CHR$ (&H1B) ; "-" ; CHR$ (0) ;
LPRINT "AAAAA" ;
LPRINT CHR$ (&H1B) ; "-" ; CHR$ (1) ;
LPRINT "AAAAA" ; CHR$ (&HA) ;
END
```

[Print Results]

Underline Canceled
 ← A A A A A A A A A A →
 ← A A A A A A A A A A →
 Underline Specified

ESC 2

[Function] Specifying 1/6-inch line feed rate

[Code] <1B> H <32> H

[Outline] The line feed rate per line is specified by 1/6 inch.

[Sample Program]

```
LPRINT "AAAAA" ; CHR$ (&HA) ;
LPRINT CHR$ (&H1B) ; "3" ; CHR$ (0) ;
LPRINT "AAAAA" ; CHR$ (&HA) ;
LPRINT CHR$ (&H1B) ; "3" ; CHR$ (50) ;
LPRINT "AAAAA" ; CHR$ (&HA) ;
LPRINT CHR$ (&H1B) ; "2" ;
LPRINT "AAAAA" ; CHR$ (&HA) ;
LPRINT "AAAAA" ;
LPRINT CHR$ (&H1B) ; "J" ; CHR$ (100) ;
LPRINT "AAAAA" ; CHR$ (&HA) ;
LPRINT "AAAAA" ; CHR$ (&HA) ;
END
```

[Print Results]

A A A A A ↑ 1/6-inch line feed
 A A A A A ↑ 0/360-inch line feed
 A A A A A ↑ 50/360-inch line feed
 A A A A A ↑ 1/6-inch line feed
 A A A A A ↑ 100/360-inch line feed
 A A A A A ↑ 1/6-inch line feed
 A A A A A

ESC @

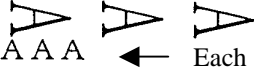
[Function]	Initializing the printer	
[Code]	<1B> H <40> H	
[Outline]	Clears data stored in the print buffer and brings various settings to the initial state (Default state).	
[Caution]	<ul style="list-style-type: none"> • Data inside the internal input buffer are not cleared. • Dip switches setting are red once again. 	
[Sample Program]	<pre>LPRINT CHR\$ (&H1B) ; " ! " ; CHR\$ (&H30) ; LPRINT CHR\$ (&H1B) ; "V" ; CHR\$ (1) ; LPRINT "AAA" ; CHR\$ (&HA) ; LPRINT CHR\$ (&H1B) ; "@" ; LPRINT "AAA" ; CHR\$ (&HA) ; END</pre>	<p>[Print Results]</p>  <p>Each setting has been initialized by the reset command.</p>

ESC D [n] k NUL

[Function]	Setting horizontal tab position
[Code]	<1B> H <44> H [<n>] k <00> H
[Range]	$1 \leq n \leq 255$ $0 \leq k \leq 32$
[Outline]	<p>Specifying a horizontal tab position.</p> <ul style="list-style-type: none"> • "n" indicates the no. of columns from the beginning to the horizontal tab position. At this time, n= set position- 1 is to be specified. For example, to set the position at 9th column, n=8 is to be specified. • k denotes the number of horizontal tab positions you want to set. • The tab position is set at position where it is "character width x n" from the line beginning. The character width, at this time, includes the rightward space amount. In double wide characters, it is made double of the ordinary case. • Tab positions can be specified are maximum 32. Specifying exceeding this is ignored. • <n> k, which denotes a setting position, is input in the increasing order and ends at <00> H. • ESC D NUL clears all the set tab positions. Following clearing, horizontal tab command is ignored.
[Caution]	<p>When the data, <n> k, is equal to or smaller than its preceding data, <n> k-1, it is assumed that tab setting is finished. If this is the case, the next data onward will be processed as normal data.</p> <p>When the data, <n> k, exceeds a 1-line print area, set the horizontal tab position, assuming "Set digit position = Maximum print digits + 1." The horizontal tab position does not change even if the character width is altered after setting the horizontal tab position.</p>
[Default]	<ul style="list-style-type: none"> • Initial value is specified for each eight characters(9th.17th.25th.33rd columns) of Font A.
[See Also]	HT
[Sample Program]	<p>[Print Results]</p> <p>See Sample Program and Print Results for HT on Page 32.</p>

ESC E n

[Function] Specifying/Canceling highlighting
 [Code] <1B> H <45> H <n>
 [Outline] Specifying/canceling the highlighting characters.

- "n" is valid only for the lowest bit (n0).
- Control by the lowest bit (n0) is shown as follows:

n0	Type
0	Canceling highlighting
1	Specifying highlighting

- This is effective to all characters.
- Dot configuration of a highlighted character includes one extra dot added at its side.
- The print result of Double printing and highlight character printing is completely same.

[Caution]
 [See Also] ESC !, ESC G

[Example]

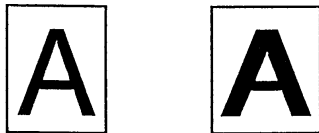

[Sample Program]

```
LPRINT CHR$ (&H1B) ; "E" ; CHR$ (0) ;
LPRINT "AAABBB" ; CHR$ (&HA) ;
LPRINT CHR$ (&H1B) ; "E" ; CHR$ (1) ;
LPRINT "AAABBB" ; CHR$ (&HA) ;
```

[Print Results]

```
A A A B B B ← Highlighting canceled
A A A B B B ← Highlighting specified
```

ESC G n

[Function] Specifying/Canceling double printing
 [Code] <1B> H <47> H <n>
 [Outline] Specifying/canceling the double printing.

- "n" is valid only for the lowest bit (n0).
- Control by n is shown as follows.

n0	Type
0	Canceling double printing
1	Specifying double printing

This is effective to all characters.

[Caution] • The print result of Double printing and highlight character printing is completely same.
 [See Also] ESC E

[Sample Program]

```
LPRINT CHR$ (&H1B) ; "G" ; CHR$ (0) ;
LPRINT "AAABBB" ; CHR$ (&HA) ;
LPRINT CHR$ (&H1B) ; "G" ; CHR$ (1) ;
LPRINT "AAABBB" ; CHR$ (&HA) ;
```

[Print Results]

```
A A A B B B ← Double Printing canceled
A A A B B B ← Double Printing specified
```

ESC J n

[Function]	Printing and Feeding paper n/203 inch
[Code]	<1B> H <4A> H <n>
[Range]	$0 \leq n \leq 255$
[Outline]	Prints data inside the print buffer and feeds paper by n/360 inch. Since an actual mechanical pitch is 1/203 inch, it is internally converted approximate to the value specified with this command. <ul style="list-style-type: none">• Specified volume does not remain.• The beginning of the line is to be considered as the next printing start position.• Initial value is not defined.

[Sample Program]

[Print Results]

See Sample Program and Print Results for ESC 2 on Page 40.

ESC R n

- [Function] Selecting the international character set
- [Code] <1B> H <52> H <n>
- [Range] $0 \leq n \leq 10$
- [Outline] Depending on the value of n, following character sets are specified.

n	Character Set
0	U.S.A.
1	France
2	Germany
3	U.K.
4	Denmark I
5	Sweden
6	Italy
7	Spain
8	Japan
9	Norway
10	Denmark II

[Default] An initial value of n is set to 8 for Japan and 0 for International.

[See Also] Character Code Table (International Character Set)

[Sample Program]

```

FOR I=0 TO 10
  LPRINT CHR$ (&H1B); "R"; CHR$ (I);
  LPRINT " #${[¥]^";
  LPRINT CHR$ (&H60); "{  }~";
  LPRINT "n="; STR$ (I);
  LPRINT CHR$ (&HA);
NEXT I
END
    
```

[Print Results]

```

#${[\]^`{|}~ n= 0
#${à°ç§^`éùè" n= 1
#${ÄÖÜ^`äöüß n= 2
£${[\]^`{|}~ n= 3
#${ÆØÅ^`æøå~ n= 4
#${ÉÄÖÅÜéäöåü n= 5
#${°\é^`ùà`è`ì n= 6
#${iñ¿^`ñ}~ n= 7
#${[¥]^`{|}~ n= 8
#${ÆØÅÜéæøåü n= 9
#${ÉÆØÅÜéæøåü n= 10
    
```

ESC V n

[Function] Specifying/Canceling 90°-right- turned characters

[Code] <1B> H <56> H <n>

[Range] $0 \leq n \leq 1$

[Outline] Specifying/canceling characters 90°-right- turned character.

- "n" means the followings.

n	Condition
0	Canceling 90°-right- turned Characters
1	Specifying 90°-right- turned Characters

[Caution] • No underlines are attached to 90°-right- turned characters .

[Default] n = 0

[Sample Program]

```
LPRINT CHR$ (&H1B) ; "V" ; CHR$ (0) ;
LPRINT "AAAAA" ;
LPRINT CHR$ (&H1B) ; "V" ; CHR$ (1) ;
LPRINT "AAAAA" ; CHR$ (&HA) ;
END
```

[Print Results]

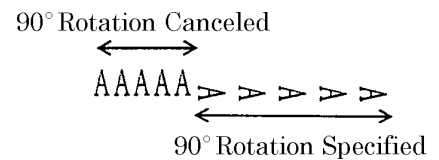

ESC a n

[Function] Aligning the characters

[Code] <1B> H <61> H <n>

[Range] $0 \leq n \leq 2$

[Outline] All the printed data within one line are aligned in the specified position.

- Depending on n value, positional alignment is carried out as in the table below:

n	Position
0	Left end alignment
1	Centering
2	Right end alignment

[Caution] • This is valid only when n is inputted at the beginning of line.

[Default] n = 0

[Sample Program]

```
LPRINT CHR$ (&H1B) ; "a" ; CHR$ (0) ;
LPRINT "AAAAA" ; CHR$ (&HA) ;
LPRINT CHR$ (&H1B) ; "a" ; CHR$ (1) ;
LPRINT "AAAAA" ; CHR$ (&HA) ;
LPRINT CHR$ (&H1B) ; "a" ; CHR$ (2) ;
LPRINT "AAAAA" ; CHR$ (&HA) ;
END
```

[Print Results]

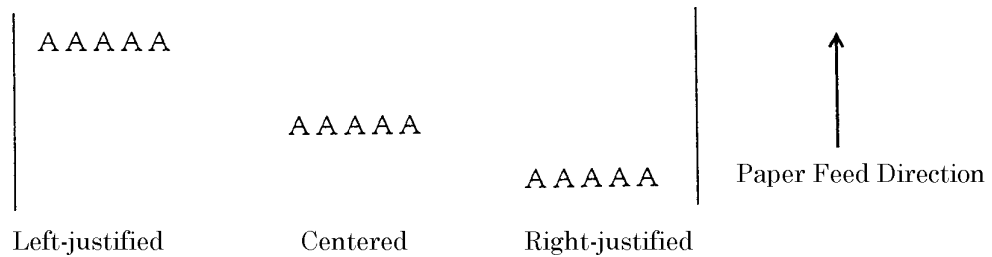

ESC c 3 n

(Parallel Interface Only)

- [Function] Selecting the paper near end sensor valid for a paper end signal output
- [Code] <1B>H<63>H<33>H<n>
- [Range] $0 \leq n \leq 255$
- [Outline] This command selects at which paper near end sensor a paper end signal should be output. Each bit for n has the following meaning:

Bit	Position	Value	
		0	1
0	Paper near end	Disabled	Enabled
1~7	Undefined		

This printer can only select one kind of paper end detection, a paper-near-end sensor. n is valid for the least significant bit (n0).

- [Caution] This command is valid only for the parallel interface.
- [Default] A default of n is what has been set with the DIP switch (DS1-1).
- [Sample Program]

```
LPRINT CHR$(&H1B);"c3";CHR$(0);
            .....When outputting the paper-end signal at the paper end
LPRINT CHR$(&H1B);"c3";CHR$(1);
            .....When outputting the paper-end signal at the paper near end
```

ESC c 4 n

- [Function] Selecting the paper near end sensor valid for print stop
- [Code] <1B>H<63>H<34>H<n>
- [Range] $0 \leq n \leq 255$
- [Outline] This command selects at which paper near end sensor printing should be stopped. Each bit for n has the following meaning:

Bit	Position	Value	
		0	1
0	Paper near end	Disabled	Enabled
1~7	Undefined		

This printer can only select one kind of paper-end detection, a paper-near-end sensor. n is valid for the least significant bit (n0).

- [Caution] If print stop is enabled, the printer will print (Feed the paper) 150 cm or an amount of data specified with the ESC n command and go off-line.
- [Default] A default of n is what has been set with the DIP switch (DS1-1).
- [Sample Program]

```
LPRINT CHR$(&H1B);"c4";CHR$(0);
            .....When stopping printing at the paper end
LPRINT CHR$(&H1B);"c4";CHR$(1);
            .....When stopping printing at the paper near end
```

ESC c 5 n

[Function] Enabling/Disabling the panel switches

[Code] <1B> H <63> H <35> H <n>

[Range] $0 \leq n \leq 255$

[Outline] Selecting the LF switch valid/invalid.

- "n" is valid only in the lowest bit (n0).
- "n" bit means the followings.

n0	Condition
0	LF SW valid.
1	LF SW invalid.

[Caution] When the panel switch is disabled with this command, the LF switch is disabled. Therefore, the paper cannot be fed by operating the LF switch.

[Default] n = 0

[Sample Program]

```
LPRINT CHR$ (&H1B) ; "c5" ; CHR$ (0) ; ..... When enabling the LF switch
LPRINT CHR$ (&H1B) ; "c5" ; CHR$ (1) ; ..... When disabling the LF switch
```

ESC d n

[Function] Printing and feeding the paper by n lines

[Code] <1B> H <64> H <n>

[Range] $0 \leq n \leq 255$

[Outline] Prints data inside the buffer and feeds paper by n lines.

- Specified line does not remain.
- The beginning of the line is to be considered as the next printing start position.

[Default] • The initial value is not defined.

[Sample Program]

```
LPRINT "AAAAA"
LPRINT CHR$ (&H1B) ; "d" ; CHR$ (2) ;
LPRINT "AAAAA" ; CHR$ (&HA) ;
END
```

[Print Results]

```

A A A A A
      |
      | 2/6-inch line feed
      |
A A A A A
```

ESC v

(Serial Interface Only)

- [Function] Transmitting the printer status
- [Code] <1B> H <76> H
- [Outline] Current printer status is transmitted..
- [Caution]
 - Status sent out consists of 1 byte whose content is as in the table below.
 - In DTR/DSR control, after receptive state of the host (DSR signal being in SPACE state) is confirmed, only 1 byte is transmitted. In XON/XOFF control, DSR signal state not being confirmed, only 1 byte is transmitted.
 - In DTR/DSR control, when the host is in unreceptive state(DSR signal being in MARK state), it waits until receptive state is created.
 - In paper end (paper near end) status, this command may be unreceptive state due to BUSY state.

Remarks. This command is valid only for serial interface model.

Bit	Function	Value	
		0	1
0	Not defined		
1	Not defined		
2	Paper end	With paper	Without paper
3	Not defined		
4	Not used	Fixed to 0	–
5	Not defined		
6	Not defined		
7	Not defined		

[Sample Program]

```

OPEN "COM1:N81NN" AS #1 ;
PRINT #1, CHR$ (&H1B) ; "v" ;
A$ = INPUT$ (1, #1) ;
CLOSE #1
END
    
```

ESC { n

[Function] Specifying/Canceling Inverted Characters

[Code] <1B> H <7B> H <n>

[Range] $0 \leq n \leq 255$

[Outline] Specifying/Canceling inverted characters.

- "n" is valid only for the lowest bit (n0).
- Bit n (n0) means the followings.

n0	Condition
0	Canceling inverted characters
1	Specifying inverted characters

- [Caution]
- Inverted printing means printing the line at 180°turned.
 - This is valid only when this is specified at the beginning of a line.

[Default] n = 0

[Sample Program]

```
LPRINT CHR$ (&H1B) ; "{" ; CHR$ (0) ;
LPRINT "AAAAA" ; CHR$ (&HA) ;
LPRINT "BBBBB" ; CHR$ (&HA) ;
LPRINT CHR$ (&H1B) ; "{" ; CHR$ (1) ;
LPRINT "AAAAA" ; CHR$ (&HA) ;
LPRINT "BBBBB" ; CHR$ (&HA) ;
END
```

[Print Results]

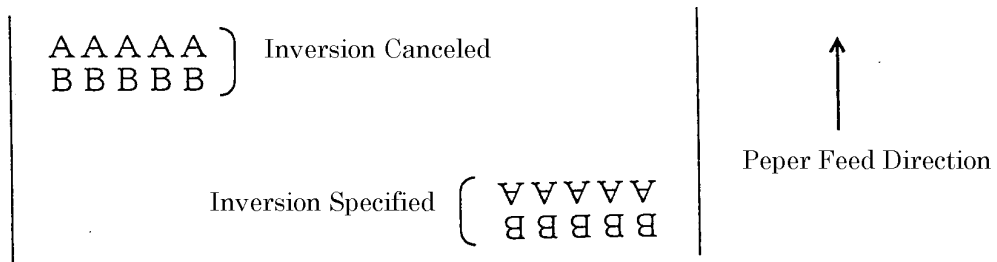

ESC \$ n1 n2

- [Function] Specifying the absolute positions
- [Code] <1B> H <24> H <n1> <n2>
- [Range] $0 \leq n1 \leq 255$
 $0 \leq n2 \leq 1$
- [Outline] The printing start position is specified in the number of dots (1/203 inch unit) from the beginning of line.
 - The number of dots is divided by 256, whose quotient is taken as n2 and the residual as n1.
 - Therefore, the printing start position is equal to $n1 + n2 \times 256$ from the beginning of line..
- [Caution] • Specifying beyond the line end is ignored.
- [Default] • The initial value is not specified.
- [See Also] ESC ¥
- [Sample Program]

```
LPRINT CHR$ (&H1B) ; "$" ;
LPRINT CHR$ (0) ; CHR$ (0) ; "A" ;
LPRINT CHR$ (&H1B) ; "$" ;
LPRINT CHR$ (50) ; CHR$ (0) ; "B" ;
LPRINT CHR$ (&H1B) ; "$" ;
LPRINT CHR$ (0) ; CHR$ (1) ; "C" ;
LPRINT CHR$ (&HA) ;
LPRINT CHR$ (&H1B) ; "$" ;
LPRINT CHR$ (100) ; CHR$ (0) ; "A" ;
LPRINT CHR$ (&H1B) ; "¥" ;
LPRINT CHR$ (&HC2) ; CHR$ (&HFF) ; "B" ;
LPRINT CHR$ (&HA) ;
END
```

[Print Results]

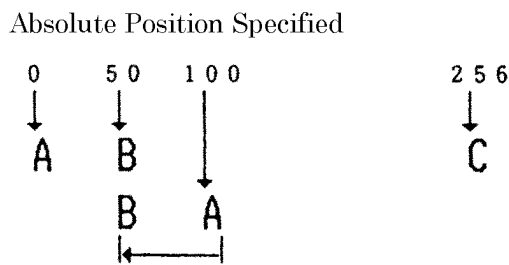

Relative Position Specified — 62

ESC ¥ n1 n2

[Function]	Specifying the relative positions
[Code]	<1B> H <5C> H <n1> <n2>
[Range]	$0 \leq n1 \leq 255$ $0 \leq n2 \leq 255$
[Outline]	<p>The printing start position is specified in the number of dots(1/203 inch unit) from the current position.</p> <ul style="list-style-type: none"> • Rightward direction is taken as plus and leftward direction as minus. • To specify N dot in minus (left) direction, use a complement of N for assignment. $-N \text{ dots} = 65536 - N$ • The number of dots is divided by 256, whose quotient is taken as n2 and the residual as n1.
[Caution]	<ul style="list-style-type: none"> • Specifying exceeding the top of line or the end of line is ignored.
[Default]	<ul style="list-style-type: none"> • The initial value is not specified.
[See Also]	ESC \$
[Sample Program]	[Print Results]
	See Sample Program and Print Results for ESC \$ on Page 53.

GS k n [d] k NUL

[Function] Printing the bar code

[Code] <1D> H <6B> H <n> [<d>] k <00> H

[Range] $0 \leq n \leq 7$

[Outline] Specifying a type of bar code and printing bar codes.

- The beginning of line is considered as the next printing start position.
- Depending on the value of n, the following bar code can be selected.

d indicates a character code to be printed and k indicates the number of character to be printed.

n	Bar Code System	Maximum Columns
0	UPC-A	–
1	UPC-E	–
2	JAN13 (EAN)	–
3	JAN 8 (EAN)	–
4	CODE 39	13
5	ITF	22
6	CODABAR (NW-7)	17
7	CODE 128	16

- [Caution]
- When data being held in the print buffer, this command is ignored.
 - Regardless of the specified feed pitch, this command feeds the paper to be required to print a bar code.
 - If the character code d cannot be printed in the respective bar code system, the bar code so far will be printed, processing the subsequent data as normal data.
 - When a bar code whose number of characters to be printed is fixed has been selected, the number of characters k have to be always made equal to the number of characters to be printed. (The bar code is not printed when not matching.)
 - When the horizontal direction exceeds one line length, the excess part is not printed.

[Default] • The initial value is not specified.

[Description of Bar Codes] <For print examples, see Page 58.>

UPC-A This bar code, consisting of numerals only, has a fixed length of 12 columns; a 11-column number entered from the host or application software plus a check column(12th column) automatically calculated inside the printer. If the 12th-column numeral is sent from the host, the entire bar code will be printed as it is.

UPC-E This bar code, consisting of numerals only, has a fixed length of 8 columns; the first number system character is "0" stationary. A 12-column numeral entered from the host or application software is compressed to 8 columns with a check column and printed. The 12th-column check column is automatically calculated inside the printer and sent from the host, the entire bar code will be printed, compressed to 8 columns.

- JAN-13(EAN) This bar code, consisting of numerals only, has a fixed length of 13 columns; a 12-column number entered from the host or application software plus a check column(13th column) automatically calculated inside the printer. If the 13th-column numeral is sent from the host, the entire bar code will be printed as it is.
- JAN-8(EAN) This bar code, consisting of numerals only, has a fixed length of 8 columns; a 7-column number entered from the host or application software plus a check column(8th column) automatically calculated inside the printer. If the 8th-column numeral is sent from the host, the entire bar code will be printed as it is.
- CODE39 This bar code, consisting of uppercase alphabets and numerals, has a variable length of columns. A start/stop code "*" is automatically added by the printer. Available characters include a space and " \$ % + - . / 0 1 2 3 4 5 6 7 8 9 " and uppercase alphabets.
- ITF This bar code, consisting of numerals only, has a variable length of even digits. If an odd-column code is transferred, nothing will be printed.
- CODABAR (NW-7)
This bar code, consisting of alphanumerals, has a variable length of columns. Available characters include " 0 1 2 3 4 5 6 7 8 9 A B C D \$ + - . / : " A start/stop code is required; any one of A, B, C, and D is used.
- CODE128
- This bar code consists of all of 128 ASCII code characters and has a variable length of columns. This printer supports the code subsets A, B, and C. By prefixing a transfer code with any one character of A, B, and C, you can select the code subset to start from. If not prefixed with A, B, or C, the code subset B will be selected.
 - The code subset A is the bar code consisting of standard uppercase alphabets, numerals, symbols, and special codes.
 - The code subset B is the bar code consisting of standard uppercase/lowercase alphabets, numerals, symbols, control codes, and special codes.
 - The code subset C is the bar code consisting of special characters and 100 kinds of numbers ranging from 00 to 99.
 - The check digit automatically calculated inside the printer is added to the end of the entered columns to be printed.
 - Processing of the special characters
The characters above the ASCII code number 96 are considered special characters. The following lists the converted characters for entering these characters.

ASCII Code	Converted Character	Subset Code A	Subset Code B	Subset Code C
96	80h	FNC 3	FNC 3	-N/A-
97	81h	FNC 2	FNC 2	-N/A-
98	82h	SHIFT	SHIFT	-N/A-
99	83h	CODE C	CODE C	-N/A-
100	84h	CODE B	FNC 4	CODE B
101	85h	FNC 4	CODE A	CODE A
102	86h	FNC 1	FNC 1	FNC 1

The following exemplifies a selection of the code subset as a method to utilize the special characters.

<Selection of Code Subset>

- Initial selection: Enter any one character of A, B, and C.
- Conversion on the way: Enter any one character of 82h through 85h

Example) When initially testing with the code subset B, and then, printing the bar code, "123," with the code subset A

- Input code :
- Bar code data : <CODE B>TEST<CODE A>123

[Sample Program]

```
LPRINT CHR$ (&H1D) ; "H" ; CHR$ (2) ;
LPRINT CHR$ (&H1D) ; "k" ;
LPRINT CHR$ (4) ;
LPRINT "123" ; CHR$ (0) ;
```

[Print Results]

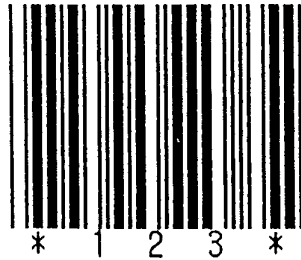

When the data "123" is printed with the code 39

[Description of Bar Codes]

UPC-A, UPC-E, JAN-13 (EAN), JAN-8 (EAN), CODE39, ITF, CODABAR, CODE128

Type	Print Sample	Outline of Symbol	Max. column
UPC-A	Bar Code 1 	12-column fixed-length bar code consisting of numerals only	–
UPC-E	Bar Code 2 	8-column fixed-length bar code consisting of numerals only. Abbreviated version of UPC-A	–
JAN-13	Bar Code 3 	13-column fixed-length bar code consisting of numerals only	–
JAN-8	Bar Code 4 	8-column fixed-length bar code consisting of numerals only	–
CODE39	Bar Code 5 	Variable-length bar code consisting of alphabets and numerals. The start/stop code "*" is automatically added.	13
ITF	Bar Code 6 	Even-column variable-length bar code consisting of numerals only	22
CODABAR (NW-7)	Bar Code 7 	Variable-length bar code consisting of alphanumerals. Any one of A, B, C, and D is required as the start/stop code.	17
CODE128	Bar Code 8 	Variable-length bar code consisting of all 128 ASCII code characters.	16

Printing is done depending on bar code specification type, number of print digits, bar code height, width (Magnification), visible code presence, and bar code data specification.

GS w n

[Function] Specifying the horizontal size(Scale factor) of bar code

[Code] <1D> H <77> H <n>

[Range] $2 \leq n \leq 4$

[Outline] Selecting bar code width.
n denotes the number of dots in fine element width.

[Default] $n = 3$

[Sample Program]

```

LPRINT CHR$ (&H1D) ; "h" ; CHR$ (50) ;
LPRINT CHR$ (&H1D) ; "w" ; CHR$ (2) ;
GOSUB *BC
LPRINT CHR$ (&H1D) ; "h" ; CHR$ (80) ;
LPRINT CHR$ (&H1D) ; "w" ; CHR$ (3) ;
GOSUB *BC
LPRINT CHR$ (&H1D) ; "h" ; CHR$ (120) ;
LPRINT CHR$ (&H1D) ; "w" ; CHR$ (4) ;
GOSUB *BC
END
*BC :
LPRINT CHR$ (&H1D) ; "k" ;
LPRINT CHR$ (4) ;
LPRINT "12" ; CHR$ (0) ;
RETURN
    
```

[Print Results]

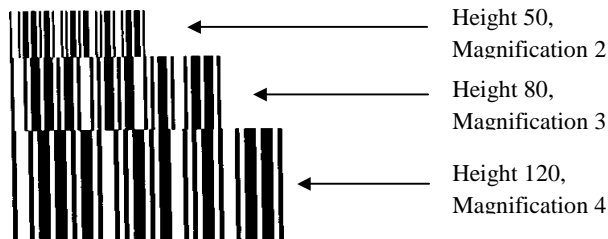

GS h n

[Function] Specifying the height of the bar code

[Code] <1D> H <68> H <n>

[Range] $1 \leq n \leq 255$

[Outline] Selecting bar code height.
n denotes the number of dots in the vertical direction.

[Default] $n = 162$

[See also] GS k, GS w

[Sample Program]

[Print Results]

See Sample Program and Print Results for GS w as above.

GS H n

- [Function] Selecting the printing position of HRI characters
- [Code] <1D> H <48> H <n>
- [Range] $0 \leq n \leq 3$
- [Outline] Selecting printing position of HRI characters in printing bar codes.

- "n" means the followings.

n	Printing Position
0	No printing
1	Above the bar code
2	Below the bar code
3	Both above and below the bar code

The visible code refers to the bar code-turned characters so that you can read them.

- [Caution] The visible code is printed in the font selected with GS f. Specify before the GS k command.

[Default] n = 0

[See Also] GS f

[Sample Program]

```

LPRINT CHR$ (&H1B) ; "3" ; CHR$ (5) ;
LPRINT CHR$ (&H1D) ; "h" ; CHR$ (50) ;
LPRINT CHR$ (&H1D) ; "H" ; CHR$ (0) ;
GOSUB *BC
LPRINT CHR$ (&H1D) ; "H" ; CHR$ (1) ;
GOSUB *BC
LPRINT CHR$ (&H1D) ; "H" ; CHR$ (2) ;
GOSUB *BC
LPRINT CHR$ (&H1D) ; "H" ; CHR$ (3) ;
GOSUB *BC
END
*BC :
LPRINT CHR$ (&H1D) ; "k" ;
LPRINT CHR$ (4) ;
LPRINT "12" ; CHR$ (0) ;
LPRINT CHR$ (&HA) ;
RETURN
    
```

[Print Results]

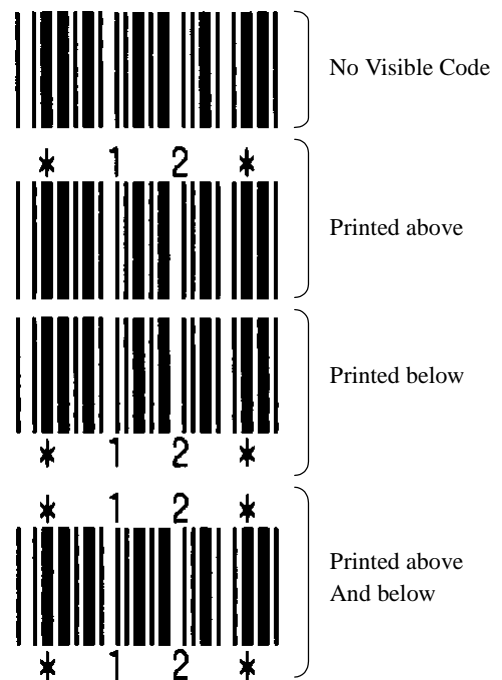

GS f n

[Function] Selecting the font of HRI code

[Code] <1D> H <66> H <n>

[Range] n = 0, 1

[Outline] Selecting the font of HRI code in printing bar code.

The type of font can be printed by selecting n is as follows.

n	Font
0	Font A
1	Font B

The visible code refers to the bar code-turned characters so that you can read them.

[Caution] The visible code is printed at the position specified with GS h.

[Default] n = 0

[See Also] GS H

[Sample Program]

```

LPRINT CHR$ (&H1D) ; "h" ; CHR$ (50) ;
LPRINT CHR$ (&H1D) ; "H" ; CHR$ (2) ;
LPRINT CHR$ (&H1D) ; "f" ; CHR$ (0) ;
GOSUB *BC
LPRINT CHR$ (&H1D) ; "f" ; CHR$ (1) ;
GOSUB *BC
END
*BC :
LPRINT CHR$ (&H1D) ; "k" ;
LPRINT CHR$ (4) ;
LPRINT "123" ; CHR$ (0) ;
LPRINT CHR$ (&HA) ;
RETURN
    
```

[Print Results]

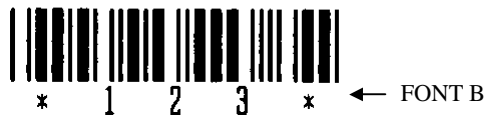

GS * n1 n2 [d] n1 × n2 × 8

- [Function] Defining the download, bit image
- [Code] <1D> H <2A> H <n1> <n2> [<d>] n1×n2×8
- [Range] 1 ≤ n1 ≤ 255
1 ≤ n2 ≤ 48
n1 × n2 ≤ 1311
- [Outline] Defines downloading bit images of the number of dots specified by n1/n2.
 - The numbers of dots are n1 × 8 in horizontal direction and n2 × 8 in vertical direction.
 - d indicates bit image data.
 - The download bit image thus defined remains effective until redefinition, ESC @ execution, ESC &, or power OFF takes place.
- [Caution]
 - A download character and a download bit image can not be defined simultaneously. With this command executed, defined content of a download character is cleared.
 - Relations between the bit image data and the dot defined are shown below:
- [See Also] GS /, ESC &

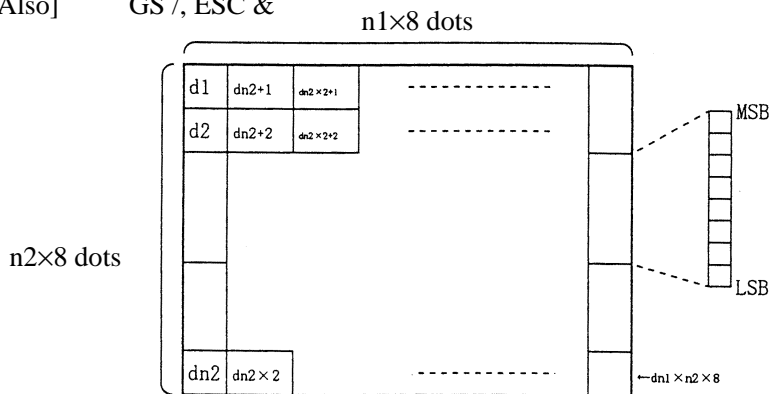

[Sample Program]

```

GOSUB *IMG
LPRINT CHR$ (&H1D); "/" ; CHR$ (0) ;
LPRINT CHR$ (&H1D); "/" ; CHR$ (1) ;
LPRINT CHR$ (&H1D); "/" ; CHR$ (2) ;
LPRINT CHR$ (&H1D); "/" ; CHR$ (3) ;
END
*IMG :
N1 = 8 : N2 = 8
LPRINT CHR$ (&H1D); "*" ;
LPRINT CHR$ (N1) ; CHR$ (N2) ;
FOR J=1 TO N1*8
  FOR I=1 TO N2
    LPRINT CHR$ (J) ;
  NEXT I
NEXT J
RETURN
END
    
```

[Print Results]

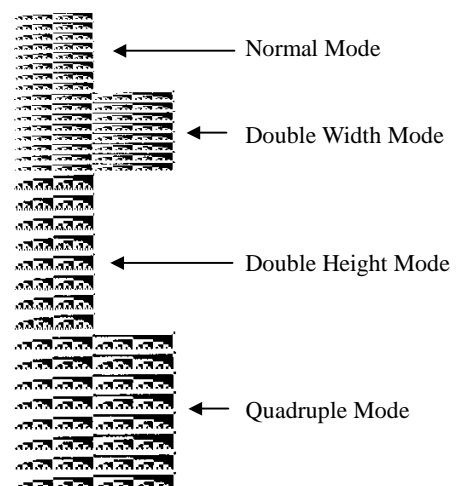

GS :

- [Function] Starting/Ending macro definition
- [Code] <1D> H <3A> H
- [Outline] Specifying starting / ending macro definition.
Means termination when received while defining a macro.
- [Caution] Maximum content available for macro definition is 2048 bytes. A portion exceeding 2048 bytes is not defined.
 - Even with ESC @ (initialization of the printer) having been executed, defined content is not cleared. Therefore, it is possible to include ESC @ into the content of macro definition.
 - Normal printing operation is carried out even while in macro definition
- [Default]
 - Initially, Macro is not specified.
- [See Also] GS ^

[Sample Program]

```
LPRINT CHR$ (&H1D) ; " : " ;
LPRINT "+ - - - +" ; CHR$ (&HA) ;
LPRINT "|           |" ; CHR$ (&HA) ;
LPRINT "+ - - - +" ; CHR$ (&HA) ;
LPRINT CHR$ (&H1D) ; " : " ;
LPRINT CHR$ (&H1D) ; " ^ " ;
LPRINT CHR$ (2) ; CHR$ (10) ;
LPRINT CHR$ (0) ;
END
```

[Print Results]

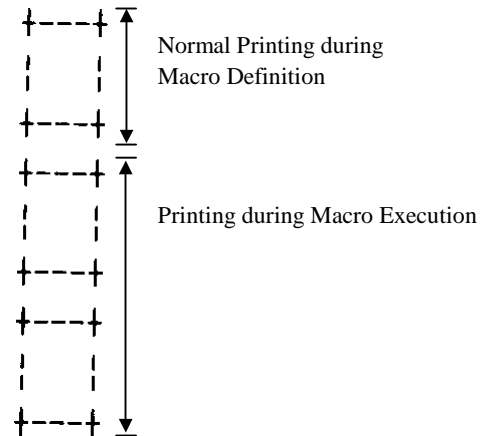

GS ^ n1 n2 n3

[Function] Executing the macro
 [Code] <1D> H <5E> H <n1> <n2> <n3>
 [Range] $0 \leq n1 \leq 255$

$0 \leq n2 \leq 255$

$0 \leq n3 \leq 1$

[Outline] Executing contents defined in macro.

- "n1~n3" indicate as follows:

n1 : The number of times of macro execution

n2 : Waiting time on macro execution

Waiting time of $n2 \times 100$ msec is given for every execution.

n3 : Macro execution mode

n3	Mode
0	Continuous execution
1	Execution by LF SW

Continuous execution: The Macro is executed n1 times continuously at the time intervals specified by n2.

Execution by FEED S: After waiting for lapse of time specified by n2, the ALAME LED flickers and the LF switch is waited to be pressed. When it is pressed, the macro is executed once.

This action is repeated n1 times.

- [Caution]
- When this command is received while in macro definition, suspension of macro definition is indicated. At this time, the defined content is cleared.
 - No execution takes place when macro is held undefined or $n1=0$.
 - While in macro execution with $n3=1$, paper feed with the LF SW is not available.

[Default] • Initially, this command is not specified.

[See Also] GS :

[Sample Program]

[Print Results]

See Sample Program and Print Results for GS : on Page 64.

DC2 A n

- [Function] Selecting a printing speed
 [Code] <12>H<41>H<n>
 [Range] $0 \leq n \leq 1$
 [Outline] This command specifies a printing command. n is valid only for the least significant bit.

n0	Printing Speed
0	Standard print
1	High-speed print

- [Caution] If a printing amount is too much for one line, a standard speed will be assumed. Bar code printout and download bit image printout are automatically done at a standard speed. At high-speed printout, printing quality may be deteriorated.
 [Default] n = 1

DC3 n

- [Function] Switching the Red/Black printing
 [Code] <13>H<n>
 [Range] $0 \leq n \leq 255$
 [Outline] This command selects/deselects black/red printout. n is valid only for the least significant bit (n0).

n0	Black based paper	n0	Red based paper
0	Deselects red printout	0	Deselects black printout
1	Selects red printout	1	Selects black printout

- When deselected : Assumes a standard power-on pulse rate
 When selected : Increases a power-on pulse rate to change coloring.
 [Caution] This command is valid only at the beginning of the line. It functions when special purpose paper is used. Printing color becomes thicker on normal thermal paper.
 [Default] n = 0
 [Sample Program]

```
LPRINT "ABCDEFGH" ;CHR$ (&HA) ;
LPRINT CHR$ (&H13) ; CHR& (1) ;
LPRINT "ABCDEFGH" CHR& (&HA) ;
END
```

[Print Result]

When the normal thermal paper is used

```
ABCDEFGH ← Black print
ABCDEFGH ← Red print
```

When the special purpose paper is used

```
ABCDEFGH ← Standard print
ABCDEFGH ← High-temperature print
```

FF (Only When Label Printer is Selected)

- [Function] Printing and paper feeding to the top of the label
- [Code] <0C>H
- [Outline] This command prints the data in the printer buffer and searches for the head of the next label.
- [Caution] This command is valid only when the label printer is selected with DS1-5. It is ignored when the thermal paper is specified. After sending one label worth of print data, be sure to send this command or GS FF command. After the user intentionally moved the label paper, this command cannot search for the head of the label properly.
- [See Also] GS FF, GS <

[Sample Program]

```
LPRINT "ABC" ; CHR$ (&HA) ;
LPRINT "123" ; CHR$ (&HC) ;
LPRINT "HHHHH" ; CHR$ (&HA) ;
LPRINT "ggggg" ; CHR$ (&HC) ;
END
```

[Print Result]

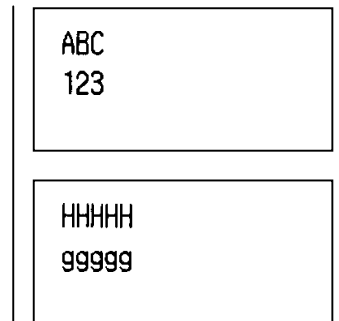

GS FF (Only When Label Printer is Selected)

- [Function] Printing and discharging the label(Cutting included)
- [Code] <1D>H<0C>H
- [Outline] This command prints the data in the printer buffer and cuts and discharges the label. If this command is executed, the printer will discharge the label to the cutting position and flicker the PAPER lamp to stop. After cutting the label, press the FEED switch to search for the head of the next label.
- [Caution] This command is valid only when the label printer is selected with DS1-5. It is ignored when the thermal paper is specified. After sending one label worth of print data, be sure to send this command or FF command. After the user intentionally moved the label paper, this command can not search for the head of the label properly.
- [See Also] FF, GS <

GS C0 m n

- [Function] Setting the numbering print mode
- [Code] <1D>H<43>H<30>H<m><n>
- [Range] $0 \leq m \leq 5$
 $0 \leq n \leq 5$
- [Outline] This command sets the numbering (serial number counter) print mode. *m* denotes the number of print columns.
- m* = 0 Prints the digits indicated by a numeral. In this case, *n* has no meaning.
- m* = 1 to 5 Indicates the maximum number of columns to be printed. If a counter value is larger than this the number of columns set with this command, the printer will print the lower *m* -digits of the counter value.
- n* specifies a printing position within the printing columns.
- n* = 0 Prints the data right justified. The blank columns are spaced.
- n* = 1 Prints the data right justified. The blank columns are filled with "0".
- n* =2 Prints the data left justified. The right blank columns are spaced.
- [Caution] If either *m* or *n* has a value beyond their ranges, that setting will become invalid.
- [See Also] GS C1, GS C2, GS c, GS C
- [Default] *m* = 0, *n* = 0

[Sample Program]

```

LPRINT CHR$ (&H1D) ; "C0" ;           * CNT
LPRINT CHR$ (0) ; CHR$ (0) ;           FOR I=1 TO 5
GOSUB * CNT                             LPRINT CHR$ (&H1D) ; "c" ;
LPRINT CHR$ (&H1D) ; "C0" ;           NEXT I
LPRINT CHR$ (1) ; CHR$ (0) ;           LPRINT CHR$ (&HA) ;
GOSUB * CNT                             RETURN
LPRINT CHR$ (&H1D) ; "C0" ;
LPRINT CHR$ (3) ; CHR$ (0) ;
GOSUB * CNT
LPRINT CHR$ (&H1D) ; "C0" ;
LPRINT CHR$ (3) ; CHR$ (1) ;
GOSUB * CNT
LPRINT CHR$ (&H1D) ; "C0" ;
LPRINT CHR$ (3) ; CHR$ (2) ;
GOSUB * CNT
END
    
```

[Print Result]

```

12345 ←————— Counts from 1 to 5 at m = 0 and n = 0.
67890 ←————— Counts from 6 to 10 at m = 1 and n = 0.
 11 12 13 14 15 ← Counts from 11 to 15 at m = 3 and n = 0.
016017018019020 ← Counts from 16 to 20 at m = 3 and n = 1.
21 22 23 24 25 ← Counts from 21 to 25 at m = 3 and n =2.
    
```

GS C2 n1 n2

- [Function] Setting the numbering counter
- [Code] <1D>H<43>H<3B>H<N1><3B>H<N2><3B>H<N3><3B>H<N4><3B>H<N5><3B>H
 <1D>H<43>H<32>H<n1><n2>
- [Range] $0 \leq n1 \leq 255, 0 \leq n2 \leq 255$
- [Outline] This command sets the numbering (serial number counter) value.
 $n1 + n2 \times 256$ ($n1 = \text{remainder}, n2 = \text{quotient}$) becomes a counter value.
- [Caution] If the counter is set with this command, a repeat count of the identical counter will be cleared.
 If the counter value is beyond the Range specified with the "GS C1" or "GS C;" command, the counter will be initialized.
- [Default] Not defined.
- [See Also] GS C0, GS C1, GS c, GS C;
- [Sample Program] [Print Result]
 See the sample program and print result for the GS C1 command on Page 69.

GS C; N1; N2; N3; N4; N5;

- [Function] Setting the numbering counter mode (B)
- [Code] <1D>H<43>H<3B>H<N1><3B>H<N2><3B>H<N3><3B>H<N4><3B>H<N5><3B>H
 <N1>, <N2>, <N3>, <N4>, and <N5> are character codes.
- [Range] $0 \leq N1, N2, N5 \leq 65535 \quad 0 \leq N3, N4 \leq 255$
- [Outline] This command sets the numbering (serial number counter) mode and a counter value.
- | | |
|---|---------------------------------|
| N1 | : Counter default |
| N2 | : Counter final value |
| N3 | : Counter step value |
| N4 | : Identical counter print count |
| N5 | : Counter start value |
| N1<N2 | : Count-up system |
| N1>N2 | : Count-down system |
| N1 = N2
or
N3 = 0
or
N4 = 0 | : Counter stop |

[Caution] If the N5 counter start value is beyond the counter range specified with N1 and N2, it is assumed to be N1 = N5. If each value of N1 through N5 contains a character code other than "0" through "9", the printer will invalidate the data up to that parameter and handle the subsequent data as normal print data.

[Default] N1 = 1
 N2 = 65535
 N3 = 1
 N4 = 1
 N5 = 1

[See Also] GS C0, GS C1, GS C2, GS c

[Sample Program]

```
LPRINT CHR$ (&H1D) ; "C0" ; *CNT
LPRINT CHR$ (3) ; CHR$ (0) ; FOR I=1 TO 6
LPRINT CHR$ (&H1D) ; "C" ; LPRINT CHR$ (&H1D) ; "c" ;
LPRINT "50 ; 0 ; 5 ; 2 ; 50 ; " ; NEXT I
GOSUB *CNT LPRINT CHR$ (&HA) ;
LPRINT CHR$ (&H1D) ; "C ; " ; RETURN
LPRINT "50 ; 0 ; 5 ; 2 ; 5 ; " ;
GOSUB *CNT
END
```

[Print Result] When setting a count-down range = 0 to 50, step value = 5, repeat count = 2, and start value = 50 to print a counter value.

```
50 50 45 45 40 40 ←
```

When setting a count-down range = 0 to 50, step value = 5, repeat count = 2, and start value = 5 to print a counter value.

```
5 5 0 0 50 50 ←
```

GS c

[Function] Printing the counter

[Code] <1D>H<63>H

[Outline] This command prints the serial number counter data. After setting the current counter value in the print buffer as the print data (Character string), it increments or decrements the counter according to the set count mode.

[Caution] When setting the value in the print buffer, its format depends on the GS C0 command. The count mode depends on the GS C1 or GS C; command. If the counter final value set with these commands is exceeded by executing the GS c command, the counter will be initialized to the set default.

[See Also] GS C0, GS C1, GS C2, GS C ;

[Sample Program]

[Print Result]

See the sample programs and print results for the commands on Pages 68 through 71.

GS < (Only When Label Printer is Selected)

- [Function] Initializing the printer mechanism
- [Code] <1D>H<3C>H
- [Outline] This command initializes the printer mechanism.
- [Caution] This command is valid only when the label printer is selected with DS1-5. Since it uses one label for scanning, a head search starts from the next label. The maximum label length and label spacing (Black mark) is 300 mm. Any label exceeding this limit results in an error.

GS A m n (Only When Label Printer is Selected)

- [Function] Correcting the label top position
- [Code] <1D>H<41>H<m><n>
- [Range] $0 \leq m \leq 255, 0 \leq n \leq 10$
- [Outline] This command sets the label head search position in terms of correction value for the default position. m denotes the correcting direction and valid only for the least significant bit (m0).

m 0	Correcting direction
0	Corrects in the forward direction
1	Corrects in the reverse direction

- n denotes a correction value; it is set in increments of n/203 inch.
- [Caution] This command is valid only when the label printer is selected with DS1-5. The correction value remains valid until it is re-set with this command or the power is turned on again. Any setting beyond the range is ignored.

11. CHARACTER CODESTABLE

11.1 International

	0	1	2	3	4	5	6	7	8	9	A	B	C	D	E	F
0	NUL		(SP)	0	@	P	˘	p	Ç	É	á	☼	⊥	⊥	α	≡
1			!	1	A	Q	a	q	ü	æ	í	☼	⊥	⊥	β	±
2		DC2	”	2	B	R	b	r	é	Æ	ó	☼	⊥	⊥	Γ	≥
3		DC3	#	3	C	S	c	s	á	ò	ú			⊥	π	≤
4			\$	4	D	T	d	t	ä	ö	ñ		—	⊥	Σ	∫
5			%	5	E	U	e	u	à	ò	Ñ	⊥	+	⊥	σ	∫
6			&	6	F	V	f	v	á	ú	ä	⊥	⊥	⊥	μ	÷
7			'	7	G	W	g	w	ç	ù	º	⊥	⊥	⊥	τ	≈
8			(8	H	X	h	x	è	ý	ı	⊥	⊥	⊥	Φ	°
9	HT)	9	I	Y	i	y	ë	Ö	⊥	⊥	⊥	⊥	θ	•
A	LF		*	:	J	Z	j	z	è	Ü	⊥	⊥	⊥	⊥	Ω	•
B		ESC	+	;	K	[k	{	ı	ç	⊥	⊥	⊥	⊥	δ	√
C	FF	FS	,	<	L	\	l		ı	£	⊥	⊥	⊥	⊥	∞	ˆ
D	CR	GS	—	=	M]	m	}	ı	¥	ı	⊥	=	⊥	φ	²
E			.	>	N	˘	n	˘	Ä	Pt	«	⊥	⊥	⊥	ε	■
F			/	?	O	€	o	(SP)	Á	f	»	⊥	⊥	⊥	∩	(SP)

11.2 Domestic

	0	1	2	3	4	5	6	7	8	9	A	B	C	D	E	F	
0	NUL		(SP)	0	@	P	˘	p	—	⊥	(SP)	—	夕	ミ	=	×	
1			!	1	A	Q	a	q	—	⊥	。	ア	チ	ム	ト	円	
2		DC2	”	2	B	R	b	r	—	⊥	「	イ	ツ	メ	≠	年	
3		DC3	#	3	C	S	c	s	—	⊥	」	ウ	テ	モ	≠	月	
4			\$	4	D	T	d	t	—	⊥	、	エ	ト	ヤ	▲	日	
5			%	5	E	U	e	u	—	⊥	—	オ	ナ	ユ	▲	時	
6			&	6	F	V	f	v	—	⊥		ヲ	カ	ニ	ヨ	▼	分
7			'	7	G	W	g	w	—	⊥		ア	キ	ヌ	ラ	▼	秒
8			(8	H	X	h	x		⊥	⊥	イ	ク	ネ	リ	♠	〒
9	HT)	9	I	Y	i	y		⊥	⊥	ウ	ケ	ノ	ル	♥	市
A	LF		*	:	J	Z	j	z		⊥	⊥	エ	コ	ハ	レ	♦	区
B		ESC	+	;	K	[k	{	—	⊥	⊥	オ	サ	ヒ	ロ	♣	町
C	FF	FS	,	<	L	\	l		—	⊥	⊥	ヤ	シ	フ	ワ	●	村
D	CR	GS	—	=	M]	m	}	—	⊥	⊥	ユ	ス	ヘ	ン	○	人
E			.	>	N	˘	n	˘	—	⊥	⊥	ヨ	セ	ホ	°	/	蒸
F			/	?	O	—	o	(SP)	+	⊥	⊥	ツ	ソ	マ	°	\	(SP)

11.3 International Character Codes Table

	Country	23	24	40	5B	5C	5D	5E	60	7B	7C	7D	7E
0	U.S.A.	#	\$	@	[\]	^	'	{		}	~
1	France	#	\$	à	°	Ç	§	^	'	é	ù	è	..
2	Germany	#	\$	§	Ä	Ö	Ü	^	'	ä	ö	ü	ß
3	U.K.	£	\$	@	[\]	^	'	{		}	~
4	Denmark I	#	\$	@	Æ	Ø	Å	^	'	æ	ø	å	~
5	Sweden	#	¤	É	Ä	Ö	Å	Ü	é	ä	ö	å	ü
6	Italy	#	\$	@	°	\	é	^	ù	à	ò	è	ì
7	Spain	Pt	\$	@	ı	Ñ	ı	^	'	..	ñ	}	~
8	Japan	#	\$	@	[¥]	^	'	{		}	~
9	Norway	#	¤	É	Æ	Ø	Å	Ü	é	æ	ø	å	ü
A	Denmark II	#	\$	É	Æ	Ø	Å	Ü	é	æ	ø	å	ü

APPENDIX 1. BLOCK DIAGRAM

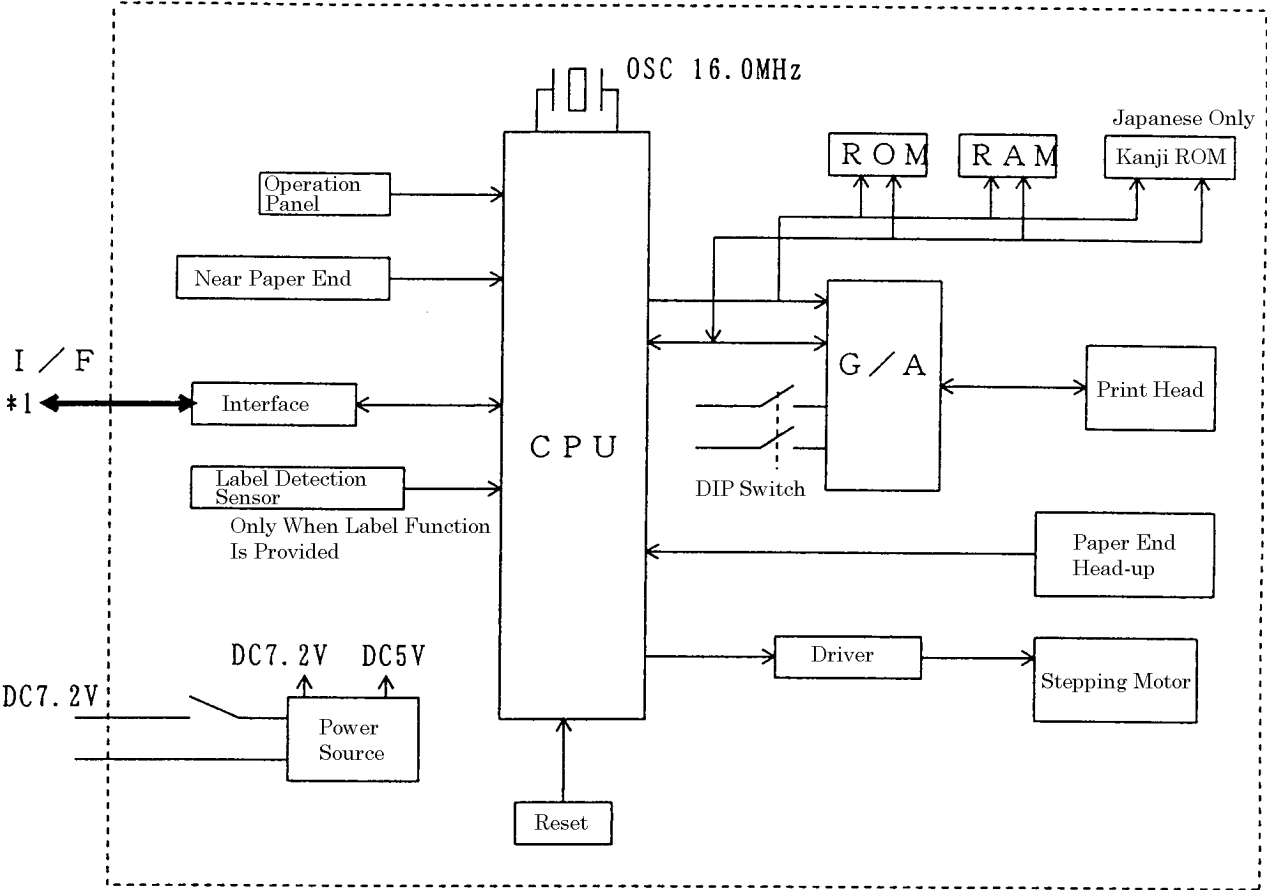

*1 Parallel Interface --- Centronics compliant
 Serial Interface --- RS-232C compliant

APPENDIX 2. OUTLINE DRAWING

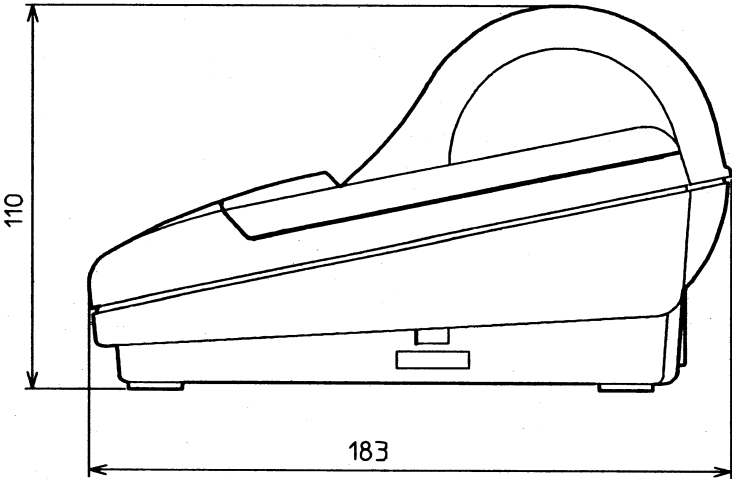
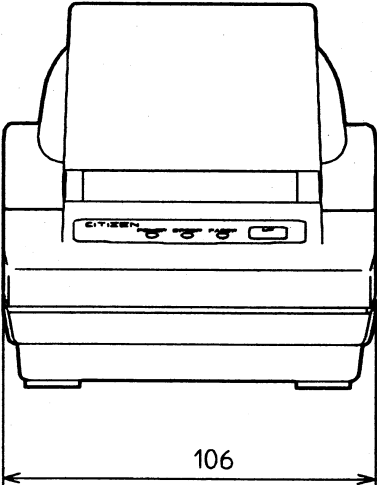
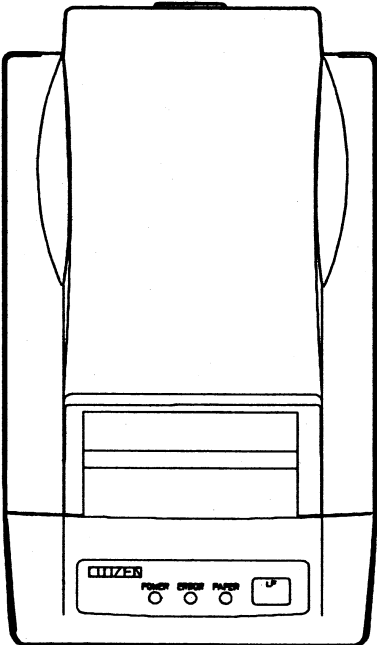

<<<German>>>

<VORSICHT>

1. Bitte lesen Sie die Bedienungsanleitung vor dem Betrieb des Geräts aufmerksam durch und bewahren Sie die Anleitung anschließend für späteres Nachschlagen an einem sicheren Platz auf.
2. Änderungen des Inhalts dieser Anleitung bleiben ohne Vorankündigung vorbehalten.
3. Die Vervielfältigung dieser Bedienungsanleitung ohne vorherige Genehmigung verstößt, auch auszugsweise, gegen das Urheberschutzrecht.
4. Niemals versuchen, in dieser Anleitung nicht erwähnte Geräteteile eigenhändig zu warten, zerlegen oder zu reparieren.
5. Bitte beachten Sie, daß wir keinerlei Haftung für Schäden übernehmen, die auf unsachgemäße Bedienung, falsche Handhabung oder eine ungeeignete Betriebsumgebung zurückzuführen sind.
6. Zur Vermeidung von Unfällen und sonstigen Problemen ist das Gerät ausschließlich auf die in der Bedienungsanleitung beschriebene Weise zu betreiben.
7. Daten sind grundsätzlich temporär, d.h. sie können nicht permanent gesichert oder über längere Zeit gespeichert werden. Es sei deshalb darauf hingewiesen, daß wir für finanzielle Schäden oder Profitrückgänge als Folge von Datenverlust, Unfällen, Reparaturen, Tests usw. keinerlei Haftung übernehmen.
8. Bitte wenden Sie sich mit Fragen oder Hinweisen auf Fehler oder Auslassungen im Text dieser Anleitung an unsere Geschäftsstelle.
9. Beachten Sie jedoch, daß wir, ungeachtet des obigen Punkts 8, keinerlei Haftung für negative Folgeerscheinungen im Zusammenhang mit dem Betrieb dieses Geräts übernehmen.

ZU BEACHTENDE SICHERHEITSMASSREGELN

Zur Vermeidung von Gefahren gegenüber dem Bediener und anderen Personen und Sachschäden sind die folgenden Vorsichtsmaßnahmen unbedingt zu beachten.

- Der folgende Text beschreibt das Ausmaß der Gefahren und potentiellen Sachschäden, die durch eine Mißachtung der Bedienungshinweise oder durch die unsachgemäße Handhabung des Geräts entstehen können.

**WARNUNG**

Die Mißachtung dieser Vorsichtsmaßregel kann zu Körperverletzungen mit möglicher Todesfolge führen.

**VORSICHT**

Die Mißachtung dieser Vorsichtsmaßregel kann zu Körperverletzungen oder Sachschäden führen.



Dieses Symbol ruft den Bediener zu erhöhter Wachsamkeit auf.



Dieses Symbol weist auf wichtige Informationen, wie z.B. Bedienungsschritte oder dergleichen, hin.

WARNUNG

- Beim Betrieb des Geräts sind die nachfolgenden Vorsichtsmaßnahmen unbedingt zu beachten. Eine Mißachtung dieser Hinweise kann zu Schäden, Funktionsstörungen, Rauchentwicklung und Brandgefahr durch Überhitzen und zu elektrischen Schlägen führen.
Der fortgesetzte Betrieb des Geräts in anormalem Zustand, wie z.B. nach einer Beschädigung, kann Funktionsstörungen, Rauchentwicklung, fremde Gerüche/Geräusche und Brände verursachen. Wenn anormale Erscheinungen beim Betrieb auftreten, sofort das Gerät stoppen, den Netzstecker abziehen, und den Fachhändler benachrichtigen. Niemals versuchen, das Gerät eigenhändig zu reparieren, um ernsthafte Gefahren zu vermeiden.
- Das Gerät vor starken Stößen und Erschütterungen, wie z.B. Tritte, Stampfen, Schläge, Herunterfallen usw., schützen.
- Das Gerät an einem gut belüfteten Platz aufstellen, und darauf achten, die Belüftungsöffnung nicht zu blockieren.
- Bei der Aufstellung des Geräts Plätze vermeiden, an denen chemische Reaktionen auftreten, wie z.B. in einem Labor, sowie Plätze mit salz- oder gashaltiger Umgebungsluft.
- Netz- und Datenkabel niemals am Kabel haltend anschließen oder abziehen. Bei Betrieb, Verrücken oder Tragen des Geräts darauf achten, daß die Kabel keiner Gewalteinwirkung ausgesetzt sind.
- Darauf achten, daß keine Fremdkörper, wie z.B. Nadeln oder Büroklammern, in das Gerät gelangen.
- Darauf achten, keine Flüssigkeiten auf dem Gerät zu vergießen oder chemische Substanzen enthaltende Sprays darüber zu versprühen. Bei versehentlichem Naßwerden das Gerät sofort ausschalten, das Stromanschlußkabel abziehen, das Netzkabel von der Steckdose trennen usw. und an einen Fachhändler wenden.
- Nicht dieses Gerät zerlegen oder modifizieren. Eine Mißachtung dieser Vorsichtsmaßregel kann zu Bränden und elektrischen Schlägen führen.
- Das Gerät nur mit der vorgeschriebenen Netzspannung und dem vorgeschriebenen Netzteil verwenden. Eine Mißachtung dieser Vorsichtsmaßregel kann Brände, elektrische Schläge und Funktionsstörungen verursachen.
- Wenn das Netzteil herunterfällt, beschädigt wird oder naß wird, sofort von der Steckdose trennen und sich an einen Fachhändler wenden.
- Das Netzkabel nicht beschädigen, brechen, modifizieren, mit Gewalt biegen/ziehen, verdrehen oder kurzschließen. Ein beschädigtes Netzteil kann Brände, elektrische Schläge und Funktionsstörungen verursachen. Wenden Sie sich bei einer Beschädigung des Netzteilkabels bitte an unsere Kundendienstvertretung.
- Wenden Sie sich bei einer Beschädigung des Netzteilkabels bitte an unsere Kundendienstvertretung.
- Das Netzteil niemals mit nassen Händen anschließen oder trennen. Hierdurch können Brände, elektrische Schläge und sonstige Probleme entstehen.
- Verpackungsbeutel sind vorschriftsgemäß zu entsorgen oder ansonsten von Kindern fernzuhalten. Kleinkinder können durch Überstreifen eines Plastikbeutels ersticken.



VORSICHTSMASSREGELN FÜR DIE AUFSTELLUNG

- Das Gerät nicht an Plätzen abstellen oder betreiben, an denen es Feuer, Feuchtigkeit oder direkter Sonnenbestrahlung ausgesetzt ist. Ebenso sind Plätze in der Nähe von Heizkörpern und sonstigen Wärmequellen zu vermeiden, an denen Umgebungstemperatur und Luftfeuchtigkeit nicht den vorgeschriebenen Betriebsbedingungen entsprechen, sowie Plätze, an denen das Gerät Öl, Metallspänen oder Staub ausgesetzt ist. Andernfalls können Funktionsstörungen sowie Rauch- und Brandentwicklung die Folge sein.
- Bei der Aufstellung des Geräts Plätze vermeiden, an denen chemische Reaktionen auftreten, wie z.B. in einem Labor, sowie Plätze mit salz- oder gashaltiger Umgebungsluft. Hierbei besteht die Gefahr von Bränden und elektrischen Schlägen.
- Den Drucker auf einer ebenen, stabilen Tischplatte an einem gut belüfteten Platz und frei von Erschütterungen aufstellen.
- Den Drucker nicht an einem Ort aufstellen, wo sein Betrieb behindert werden kann.
- Keine Gegenstände auf den Drucker stellen und keine kleinen Gegenstände wie Papierclips oder Stifte in der Nähe liegen lassen. Diese können Betriebsstörungen verursachen, wenn sie in das Gerät gelangen.
- Keine spitzen Gegenstände wie etwa einen Kugelschreiber zur Bedienung des Bedienfelds des Druckers verwenden. Dadurch können Betriebsstörungen verursacht werden.
- Das Gerät nicht in der Nähe eines Radios oder Fernsehers verwenden und nicht zusammen mit einem Radio oder Fernseher an die gleiche Steckdose anschließen. Hierdurch können Empfangsstörungen auftreten.
- Das Gerät ausschließlich mit der vorgeschriebenen Netzspannung und -frequenz betreiben. Eine Mißachtung dieser Vorsichtsmaßregel kann Brände, elektrische Schläge und Funktionsstörungen verursachen.
- Das Gerät ausschließlich mit der vorgeschriebenen Netzspannung betreiben. Eine Mißachtung dieser Vorsichtsmaßregel kann Brände, elektrische Schläge und Funktionsstörungen verursachen.
- Vergewissern, daß die für den Anschluß des Netzkabels verwendete Steckdose über eine ausreichende Kapazität verfügt.
- Das Gerät nicht zusammen mit anderen Geräten an die gleiche Steckdose anschließen oder lange Verlängerungskabel verwenden. Andernfalls können Brände und Stromausfälle die Folge sein. Nicht auf das Netzkabel treten, schwere Gegenstände darauf abstellen, das Netzkabel anderweitig belasten (ziehen, quetschen) oder den Drucker mit einem derartig belasteten Netzkabel betreiben.
- Erdungskabel niemals an ein Gasrohr anschließen, da hierbei Explosionsgefahr besteht. Vor dem Anschließen oder Trennen eines Erdungskabels unbedingt zuerst den Netzstecker aus der Steckdose ziehen.
- Beim Anschließen oder Trennen der Kabel zuerst die Netzversorgung ausschalten, einschließlich der angeschlossenen Seite, und dann an Stecker und Steckdose haltend anschließen bzw. trennen. Durch ziehen am Kabel selber kann dieses reißen oder anderweitig beschädigt werden.
- Netzkabel oder Verbindungskabel immer fest anschließen. Durch Anschluß mit umgekehrter Polarität können Innenbauteile oder Paßflächen beschädigt werden.
- Für Datensignalleitungen abgeschirmte Kabel oder verzwirbelte Doppeladernkabel verwenden, um Rauschstörungen möglichst gering zu halten. Das Kabel nicht über zu lange Strecken verlegen oder an gestörte Geräte anschließen. Durch Anschluß an gestörte Geräte kann fehlerhafter Druck aufgrund von korruptierten Daten usw. verursacht werden.
- Das Gerät an einem Platz in der Nähe einer Steckdose betreiben, wo sich der Netzstecker zum Unterbrechen der Stromversorgung jederzeit schnell und mühelos abziehen läßt.
- Wenn das Gerät längere Zeit lang nicht benutzt wird, den Stecker abziehen und die Papierrolle herausnehmen.
- Beim Transport des Geräts die Papierrolle aus dem Papierhalter nehmen.



VORSICHTSMASSREGELN FÜR DIE HANDHABUNG

Zur Vermeidung von Problemen sind bei der Handhabung des Geräts die folgenden Vorsichtsmaßnahmen zu beachten.

- Keine andere Betriebsstromquelle als das mitgelieferte Netzteil verwenden. Das Netzteil nicht für andere Zwecke verwenden.
- Nicht ohne eingelegte Papier drucken.
- Keine Fremdkörper wie Papierclips, Sicherheitsnadeln etc. in den Drucker fallenlassen.
- Darauf achten, keine Flüssigkeiten auf dem Gerät zu vergießen oder chemische Substanzen enthaltende Sprays darüber zu versprühen.
- Niemals mit spitzen Objekten, wie z.B. einem Kugelschreiber, auf das Bedienfeld drücken.
- Papierblätter niemals zum fortlaufenden Drucken mit Klebestreifen zusammenkleben. Dadurch kann der Druckkopf beschädigt werden.
- Ein bereits eingezogenes Blatt niemals gewaltsam herausziehen. Beim Öffnen/Schließen der Druckerabdeckung darauf achten, daß sich das Papier nicht verfängt. Dadurch kann Papierstau verursacht werden.
- Immer das richtige Papier verwenden. Durch Verwendung anderer Papiersorten kann die Druckqualität beeinträchtigt oder Probleme mit dem Druckkopf verursacht werden.

Zur Vermeidung von Verletzungen und Schäden

- Niemals den Druckkopf, Motor oder die Schneidklinge berühren. Dabei besteht Verletzungsgefahr.
- Bei Einschalten oder sofort nach dem Drucken keine elektrischen oder beweglichen Teile, wie z.B. Antrieb, Motor, Innenge triebe etc. berühren. Sie können sehr heiß werden und Verbrennungen verursachen.
- Darauf achten, körperliche Verletzungen und die Beschädigung anderer Objekte durch scharfe Kanten zu vermeiden.
- Bei Auftreten jeglicher Störungen während des Betriebs den Drucker sofort ausschalten, und das Netzkabel aus der Steckdose ziehen.
- Nur qualifiziertes Kundendienstpersonal ist zum Zerlegen oder Reparieren des Drucker befugt.
- Die Beseitigung von Betriebsstörungen ist qualifiziertem Fachpersonal zu überlassen. Niemals versuchen, das Gerät eigenhändig zu zerlegen.
- Beim Öffnen/Schließen der Druckerabdeckung usw. darauf achten, nicht Hände oder Finger einzuklemmen.
- Nach der Verwendung das Gerät mit dem Netzschalter ausschalten und den Netzstecker aus der Steckdose ziehen.

TÄGLICHE WARTUNG

- Bei der Wartung immer den Netzschalter des Druckers auf Aus stellen und den Stecker aus der Steckdose ziehen.
- Schmutz und Staub mit einem trockenen, weichen Tuch vom Druckergehäuse abwischen. Bei starker Verschmutzung einen Lappen in Wasser anfeuchten, auswringen und damit abwischen. Hierzu niemals flüchtige organische Lösungsmittel, wie z.B. Alkohol, Terpentin, Trichlorethan, Benzol, Keton oder chemische Staubentfernungsmittel, verwenden.
- Papierstaub mit einer weichen Bürste vom Gehäuse entfernen. Darauf achten, nicht den Druckkopf zu beschädigen.

VORSICHT:

Druckkopf und Motor werden sehr heiß. Diese Teile nicht sofort nach dem Drucken berühren. Nicht die Heizfläche des Kopfes mit bloßer Hand oder Metall berühren.

- Reinigen des Druckkopfes
 1. Die Druckwalzeneinheit unter Beachtung der Anweisungen in "4.5 Beheben von Papierstau" entfernen.
 2. Den Staub von der Oberfläche der Heizeinheit mit einem mit Äthylalkohol getränkten Wattetupfer abwischen.
 3. Die Druckwalzeneinheit wieder anbringen.

VORSICHT:

Die Wartung nicht direkt nach dem Drucken ausführen, da Druckkopf und Motor sich beim Betrieb stark erhitzen.

Nicht die Oberfläche der Heizeinheit des Druckkopfes mit der bloßen Hand oder mit Metallgegenständen berühren. Beim Abnehmen oder Wiederanbringen der Druckwalze immer den Druckkopf anheben; andernfalls könnten die Teile beschädigt werden. Die ausgebaute Druckwalzeneinheit vorsichtig zu behandeln, um Schäden zu vermeiden.

4. BETRIEB

4.1 Anschließen des Netzteils

1. Das Gerät ausschalten.
2. Den Kabelstecker des Netzteils in den Betriebsstromeingang an der Rückseite des Druckers einstecken.
3. Das Netzkabel des Netzteils zwischen Netzteil und Netzstecker anschließen.



VORSICHT:

- 1) Nur das vorgeschriebene Netzteil verwenden.
- 2) Beim Anschließen/Abtrennen des Steckers vom Netzteil immer am Stecker und nicht am Kabel anfassen.
- 3) Das Netzteil von anderen rauscherzeugenden Geräten getrennt anschließen.
- 4) Durch starkes Ziehen am Netzkabel kann dieses beschädigt werden, was zu Bränden, elektrischen Schlägen oder Reißen führen kann.
- 5) Bei Gewitter das Netzteil vom Netz trennen und nicht den Drucker betreiben, da sonst die Gefahr von Bränden oder elektrischen Schlägen besteht.
- 6) Das Netzkabel nicht in der Nähe von Heizkabeln verlegen. Die Ummantelung könnte schmelzen und zu Bränden oder elektrischen Schlägen führen.
- 7) Den Drucker immer an gut gelüfteten Orten betreiben, denn das Netzteil erwärmt sich beim Betrieb.
- 8) Immer nur an eine geeignete Netzstromquelle anschließen. Sicherstellen, daß die Steckdose ausreichende Kapazität hat. Bei unzureichender Kapazität besteht die Gefahr von Bränden durch Erhitzung.
- 9) Nach der Verwendung des Druckers oder wenn das Gerät längere Zeit über nicht verwendet werden soll immer aus Sicherheitsgründen, Netzstecker abziehen.

4.2 Anschließen des Schnittstellenkabels

1. Das Gerät ausschalten. (Paßseite eingeschlossen)
2. Die Ober- und Unterseite der Kabelkontakte prüfen, und an den Schnittstellenkontakt anschließen.
3. Die Kabelkontakte befestigen. Serielle Schnittstelle: Die Schrauben zum Befestigen festziehen.
Parallelschnittstelle: Einen Befestigungsring zum Befestigen in Pfeilrichtung drehen.
4. Das Kabel an den Hostcomputer anschließen.



VORSICHT:

- 1) Unter bezug auf "6. PARALLELE SCHNITTSTELLE" und "7. SERIELLE SCHNITTSTELLE" die Pinbelegung von Schnittstellenbuchse und -kabel prüfen. Falsche Verdrahtung kann zu Störungen oder Fehlfunktionen nicht nur am Drucker sondern auch am Hostcomputer führen.
- 2) Beim Abtrennen/Anschließen des Schnittstellenkabels immer am Stecker halten. Durch Ziehen am Kabel selber können Drahtverbindungen beschädigt werden.
- 3) Immer das Schnittstellenkabel sicher befestigen. Andernfalls kann gute Kommunikation aufgrund von Verbindungsfehlern nicht erzielt werden.

4.3 Einsetzen des Papiers

⚠ VORSICHT:

- 1) Immer die vorgeschriebene Papierrolle verwenden.
- 2) Bei Verwendung von nicht vorschriftsgemäßem Papier kann die Druckqualität, die Lebensdauer des Druckkopfes usw. nicht garantiert werden.
- 3) Nicht Thermalpapier verwenden, wenn der Drucker für Etikettenpapier eingerichtet ist und umgekehrt. Dadurch können Fehlfunktionen am Drucker oder Schäden am Druckkopf erzeugt werden.

1. Die Konvexfläche hinten an der Druckerabdeckung halten und nach oben heben.
2. Die Vorderseite der Papierrolle fast im rechten Winkel halten.

⚠ VORSICHT:

- 1) Die Druckerabdeckung ist nicht stationär (öffnen/schließen). Nach dem Abnehmen sicherstellen, daß sie nicht verlorengeht oder beschädigt wird.
- 2) Keine ausgefranst oder umgeknickten Papierenden der Papierrolle einsetzen, da dies zu Papierstau oder Einzugsfehlern führen kann.

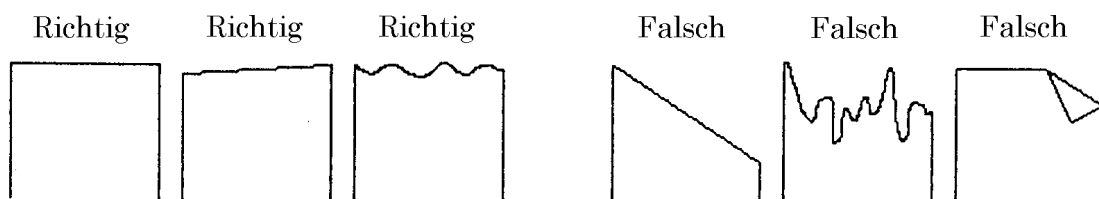

- 3) Sicherstellen, daß das Gerät eingeschaltet ist.
- 4) Den Kopfanhebe-Hebel zu dieser Seite ziehen, um den Druckkopf anzuheben.
- 5) Wenn sich weiteres Papier auch nach der Papier-Verbraucht-Anzeige im Gerät befindet, die Papierrolle entfernen, wie im Kapitel "4.4 Entnehmen der eingesetzten Papierrolle" beschrieben.
- 6) Die Vorderkante der Papierrolle gerade in den Papiereinzugschacht einsetzen.
- 7) Die Papierrolle fest in den Papierhalter setzen.
- 8) Den Kopfanhebe-Hebel zurückschieben. Die Papierrolle wird automatisch durch die Druckwalze eingezogen, um eine konstante Papiermenge vorzuschieben. (Wenn Auto-Laden aktiviert ist.) (Für Etikettenpapier wird es bis zur Druck-Startposition am 2. Blatt eingezogen.)
- 9) Die Druckerabdeckung anbringen.

⚠ VORSICHT:

- 1) Wenn die Papierrolle schlaff ist, das Papier zurückwickeln, um den Durchhang zu beheben.
- 2) Wenn die Papierrolle geneigt ist, den Kopfanhebe-Hebel heben, um die Papierrollenposition zu korrigieren oder die Papierrolle herausnehmen und erneut einsetzen.
- 3) Nicht die Druckerabdeckung während des Drucks öffnen.
- 4) Nicht die Papierrolle beim Drucken halten oder drücken, da dies zu Papierstau führen kann.

- 5) Wenn das Papier eingesetzt ist, wird der Drucker zum Druck vorbereitet. Beachten Sie, daß falls Daten im Pufferspeicher verbleiben, der Drucker nach dem Einsetzen des Papiers automatisch mit dem Druck beginnt.
- 6) Nicht den Drucker mit entfernter Abdeckung betreiben, da dies zu Fehlfunktionen oder Sensorabweichungen führen kann.

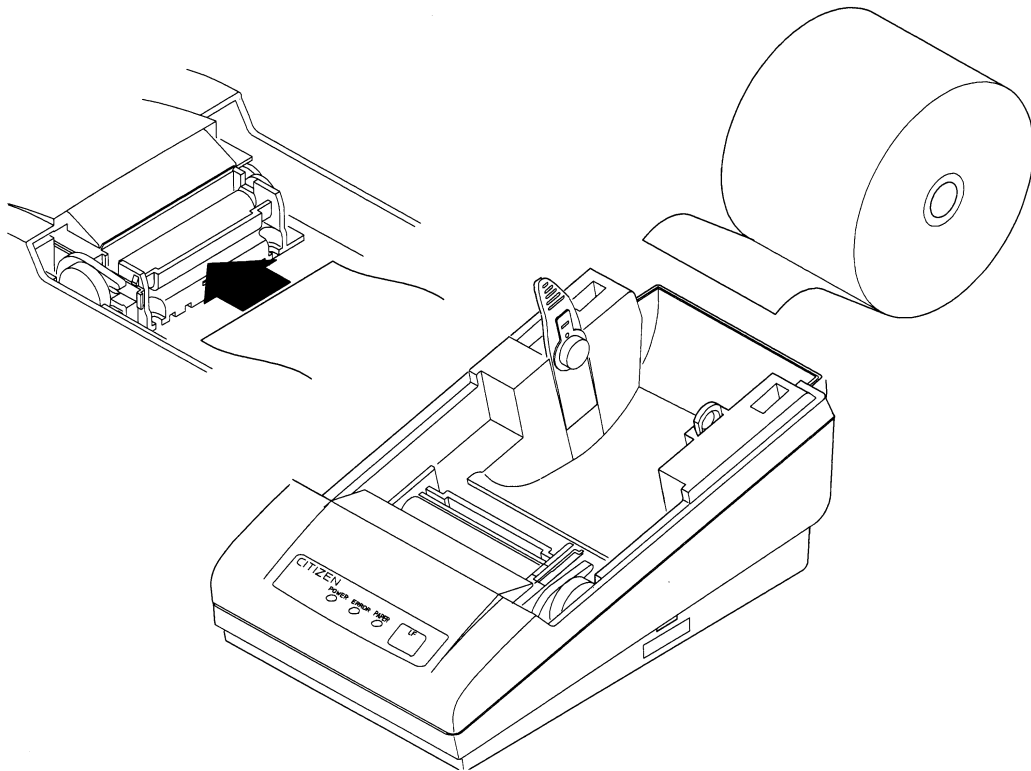

4.4 Entnehmen der eingesetzten Papierrolle

1. Die Druckerabdeckung entfernen.
2. Den Kopfanhebe-Hebel heben.
3. Vorsichtig das Papier zur nahen Seite herausziehen. Wenn die Papierrolle verbleibt, vor dem Herausziehen kurz vor dem Papiereinführungsschlitz abschneiden.

VORSICHT:

- 1) Nicht die Papierrolle in gegenrichtung ziehen.
- 2) Wenn dies bei Etikettenpapier ausgeführt wird, können sich die Etiketten lösen.
- 3) Niemals das Papier mit gesenktem Kopfanhebe-Hebel herausnehmen, da der Druckkopf beschädigt werden könnte.
- 4) Der Druckermechanismus kann sich beim Drucken stark erhitzen, deshalb muß vorsichtig gearbeitet werden.

4.5 Beseitigen von Papierstau

1. Das Gerät ausschalten.
2. Die Druckerabdeckung entfernen.
3. Die Papierrolle in der Nähe des Papiereinzugschachts abschneiden.
4. Den Kopfanhebe-Hebel anheben.
5. Die blauen Hebel an beiden Seiten der Druckwalzeneinheit heben, um die Einheit vorsichtig zu entfernen.
Die Druckwalzeneinheit kann durch manuelles Anheben der blauen Hebel abgenommen werden.
6. Die restlichen Papierrolle vollständig aus dem Papierpfad entfernen.
7. Wenn Etikettenpapier verwendet wird, können Klebstoffreste haftenbleiben. Einen weichen Lappen in Alkohol tauchen und Reste sorgfältig abwischen, um nicht den Druckkopf zu beschädigen.
8. Unter Bestätigung der Richtung der Druckwalzeneinheit diese in den Mechanismus einsetzen. Die blauen Hebel an beiden Seiten der Einheit zum Befestigen nach unten schieben.
9. Den Kopfanhebe-Hebel absenken.

VORSICHT:

- 1) Diese Arbeit nicht sofort nach dem Drucken ausführen, da sich der Druckkopf stark erhitzt.
- 2) Beim Abnehmen der Druckwalzeneinheit immer das Gerät ausschalten.
- 3) Beim Entfernen von verbleibendem Papier nicht die Heizoberfläche des Kopfes mit bloßen Händen oder Metallgegenständen berühren.
- 4) Nicht die Druckwalzeneinheit entfernen, wenn dies nicht unbedingt erforderlich ist, wie z.B. zum Beheben von Papierstau.
- 5) Beim Wiedereinsetzen der Druckwalzeneinheit immer bestätigen, daß sie korrekt angebracht ist.
- 6) Niemals die Druckwalzeneinheit abnehmen oder anbringen, wenn der Kopfanhebe-Hebel abgesenkt ist.

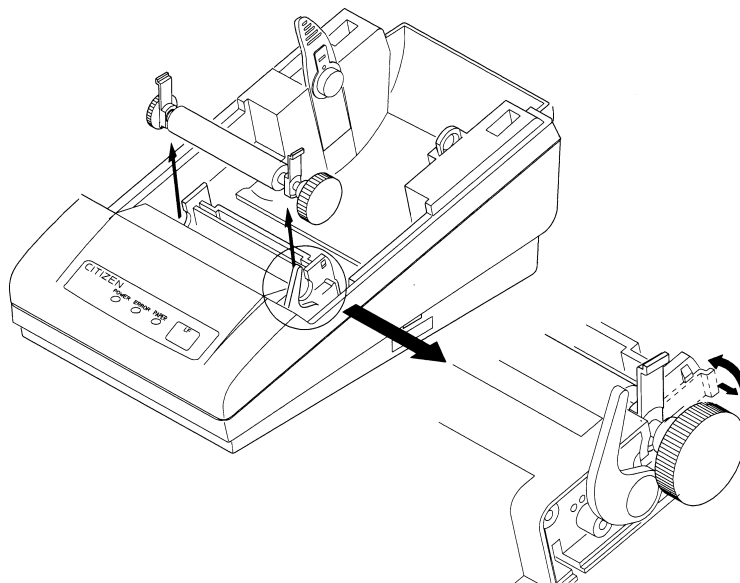

4.6 FEED-Schalterfunktion

4.6.1 Bei Verwendung von Thermalpapier

Durch Drücken des Schalters wird das Papier um 1 Zeile vorgeschoben. Wenn der Schalter gedrückt gehalten wird, wird das Papier kontinuierlich vorgeschoben.

4.6.2 Bei Verwendung von Etikettenpapier

Durch Drücken des Schalters wird das Papier um 1 Zeile vorgeschoben. Wenn der Schalter 1 Sekunde oder länger gedrückt gehalten wird, wird das Papier um ein Etikett vorgeschoben.

4.6.3 Bei Ausführung eines Makros

Wenn das ERROR-Lämpchen blinkt, während auf die Ausführung eines Makros gewartet wird, den FEED-Schalter drücken. Der Wartestatus wird fortgesetzt, bis der Schalter gedrückt wird.

4.6.4 Wenn das Etikett mit Befehl bis zur Papierschneideposition vorgeschoben wird

Das PAPER-Lämpchen blinkt. Nach dem Abschneiden des Papiers wird durch Drücken des FEED-Schalters der Anfang des nächsten Etiketts aufgesucht. Der Wartestatus wird fortgesetzt, bis der Schalter gedrückt wird.



VORSICHT:

Wenn das Etikettenpapier um 1 Zeile durch Drücken des FEED-Schalters vorgeschoben wird, wird die Kopfposition leicht verschoben. Beachten Sie, daß wenn der Druck in diesem Zustand gestartet wird, das neue Etikett leicht versetzt gedruckt wird. (Es wird empfohlen, das Papier um 1 Etikett vorzuschieben.)

4.7 Papierende-Funktion

Wenn das Druckpapier aufgebraucht ist, gibt die parallele Schnittstelle BUSY, FAULT und PE zum Host aus, und die serielle Schnittstelle gibt DTR aus, um den Druck zu stoppen. Wenn manche Daten noch im Puffer verbleiben, wird der Druck nach dem Austauschen des Papiers fortgesetzt. Tauschen Sie das Papier entsprechend den Angaben unter "4.3 Einsetzen des Papiers" aus. Nach dem Austauschen des Papiers die Ausgaben BUSY (DTR), FAULT, und PE aufheben. Einzelheiten siehe "4.7 Papierende-Funktion".

4.8 Papiermangel-Funktion

Wenn das Papier fast verbraucht ist, informiert der PNE-Sensor den Hostcomputer, daß das Papier fast verbraucht ist, indem ein Signal ausgegeben wird oder das PAPER-Lämpchen am Bedienfeld aufleuchtet. Das PAPER-Lämpchen leuchtet bedingungslos auf.

1. Wenn der PNE-Sensor erkennt, daß das Papier fast verbraucht ist, leuchtet das PAPER-Lämpchen auf.
2. Wenn PNE aktiviert ist, gibt die parallele Schnittstelle PE aus. (Standardeinstellung)
3. Drucken ist bis zu 1.5 m erlaubt. (Standardeinstellung) Nach dem Drucken oder Zuführen des Papiers um einen vorgeschriebenen Betrag gibt die parallele Schnittstelle BUSY und FAULT aus, und die serielle Schnittstelle gibt DTR aus, um den Druck zu stoppen.
4. Das Papier entsprechend dem Verfahren in "4.3 Einsetzen des Papiers" austauschen.
5. Nach dem Austauschen des Papiers die Ausgaben BUSY (DTR), FAULT und PE aufheben.

- (1) Im folgenden eine Liste der Ausgaben, die durch die Papiermangel-Funktion und Papierende-Funktion gegeben werden. Der Ausgabestatus kann mittels DIP-Schalter oder Befehl geändert werden.

DS1-1 Status	PNE Function	Einstellung der PE-Signalausgabe über Befehl	PE-Ausgabe	BUSY (DTR)/FAULT-Ausgabe	PAPER-Lämpchen
OFF	Deaktiviert	*Wenn PE gewählt ist	*Wenn PE erkannt wird	*Wenn PE erkannt wird	*Bei PNE
		Wenn PNE erkannt wird	Wenn PNE erkannt wird	Wenn PE erkannt wird	Bei PNE
ON	Aktiviert	Wenn PE gewählt ist	Wenn PE gewählt ist	Wenn der Druck aufgrund von PNE stoppt	Bei PNE
		*Wenn PNE gewählt ist	*Wenn PNE gewählt ist	*Wenn der Druck aufgrund von PNE stoppt	*Bei PNE

Markierung* :

Standardeinstellung

PNE : Papiermangel PE : Papierende

- (2) Druckmenge nach Erkennung von PNE

Wenn PNE aktiviert ist, kann eine druckbare Menge nach der PNE-Erkennung eingestellt werden. PNE wird erkannt, wenn die restliche Menge der Papierrolle etwa 2 bis 3 m beträgt. (Diese Betrag hängt von der verwendeten Papierqualität, der Papierdicke und der Betriebsumgebung ab.)

Der Standardwert beträgt 1,5 m. Bis zu 1,5 m können gedruckt werden, nachdem PNE erkannt wird. Zu diesem Zeitpunkt beträgt bei Verwendung von Papier der empfohlenen Dicke von ca. 70 µm die Restmenge des Papiers etwa 0,5 bis 1,5 m, wenn der Druckvorgang stoppt.

Dieser Wert kann über Befehl zwischen 0 und 2.55 m eingestellt werden. Je nach Betriebsumgebung und Papierqualität einstellen.

Je nach dem Einstellwert kann das Papierende früher erkannt werden (wobei der Druck stoppt).

Wenn PNE in eingeschaltetem Zustand erkannt wird, wird von diesem Punkt an eine eingestellte Druckmenge ausgeführt. (Der Standardwert beträgt 1.5 m).

4.9 Autoladefunktion

Dieser Drucker hat eine Funktion zur automatischen Papiereinstellung. Wenn der Papierendesensor, Papiermangelsensor und Kopfanhebe-Hebel aufgehoben werden, wird das Papier automatisch um eine konstante Menge in ca. 1 Sekunde zugeführt. (Bis zur Druckstartposition des zweiten Blatts bei Etikettenpapier.)

Um glatten Betrieb zu gewährleisten, den Kopfanhebe-Hebel zuletzt aufheben.

Außerdem kann der DIP-Schalter zum Aktivieren/Deaktivieren der Funktion verwendet werden. Wenn sie aktiviert ist, wird automatisches Laden nicht ausgeführt. (Bei Etikettenpapier wird das Papier zur Druckstartposition zugeführt.)

VORSICHT:

- 1) Wenn der Autoladefunktion aktiviert wird, nicht die Papierrolle berühren, da dadurch ein Papiereinzugefehler oder einseitiges Einziehen des Papiers verursacht werden kann.
- 2) Das Papier immer so einsetzen, daß es in Berührung mit der Papiereinzugwalze kommt; andernfalls kann das Papier nicht eingezogen werden, und der Druckkopf könnte beschädigt werden.
- 3) Wenn bei Etikettenpapier die Etikettensektion oder die schwarze Markierung (zwischen den Etiketten) nicht beim Zuführen des Papiers um eine konstante Menge erkannt werden kann, leuchtet das ERROR-Lämpchen am Drucker auf, und der Betrieb stoppt, weil ein Papierfehler erkannt wird.

4.10 Selbstdruckfunktion

Der Drucker hat eine Funktion, um Vorgabedruck auszuführen. Dazu wird das Gerät bei gedrücktem gehaltenem FEED-Schalter eingeschaltet. Jetzt wird die ROM-Version, die Stellung der DIP-Schalter, die verwendeten Zeichen, der japanische Schriftzeichensatz etc. ausgedruckt. Nach dem Selbstdruck schaltet der Drucker auf normalen Betriebszustand zurück.



Bei Etikettenpapier wird dieses bis zur Druckstartposition des nächsten Etiketts vorgeschoben.

VORSICHT:

- 1) Nicht diese Funktion verwenden, wenn die Papierrolle fast verbraucht ist.
- 2) Wenn die Etikettenlänge beim Drucken auf Etikettenpapier zu gering ist, wird der Druck über mehrere Etiketten fortgesetzt.
- 3) Datenkommunikation ist beim Selbstdruck nicht möglich.
- 4) Der Druckinhalt ist bei Thermalpapier und Etikettenpapier unterschiedlich.

4.11 Bedienfeld und Fehleranzeigen

1. POWER-Lämpchen (grün)
Leuchtet beim Einschalten auf.
2. ERROR-Lämpchen (rot), PAPER-Lämpchen (rot)
Zeigen durch Leuchten oder Blinken einen Fehler an.

Fehler	Anzeige		Rückstellen
	ERROR-Lämpchen	PAPER-Lämpchen	
Speicherprüfung-Fehler	 Schnelles Blinken	AUS	Kann nicht rückgestellt werden
Kopfanheben	EIN	AUS	Kopfanhebe-Hebel absenken
Kopfüberhitzung	EIN	AUS	Automatische Rückstellung durch Temperaturabfall
Papiermangel	AUS	EIN	Nach Druckstopp eine neue Papierrolle einsetzen.
Papierende	EIN	AUS	Eine neue Papierrolle einsetzen
Warten auf Makroausführung	 Langsames Blinken	AUS	Den FEED-Schalter drücken
Etikettpapierabschneiden warten	AUS	 Langsames Blinken	Den FEED-Schalter drücken
Etikettenpapier-Fehler	EIN	EIN	Für die Spezifikationen geeignetes Papier einsetzen.

< Fehler-Einzelheiten >

- Kopfanheben** ----- Tritt auf, wenn der Kopfanhebe-Hebel angehoben ist. Der Drucker kann nicht Papier zuführen oder drucken. Die parallele Schnittstelle gibt BUSY und FAULT aus, und die serielle Schnittstelle gibt DTR aus.
- Kopfüberhitzen** ----- Wenn die Temperatur des Druckkopfes ansteigt (auf 60°C oder mehr) wird ein Druckkopftemperatur-Sensor zum Stoppen des Druckens aktiviert, um den Kopf vor Überhitzung zu schützen. Die parallele Schnittstelle gibt BUSY und FAULT aus, und die serielle Schnittstelle gibt DTR aus. Wenn die Temperatur absinkt (auf ca. 55°C) wird der Druck automatisch fortgesetzt.
- Papiermangel** ----- Wenn der Durchmesser der Papierrolle abnimmt, reagiert der Papiermangel-Sensor, um darauf hinzuweisen, daß die Papierrolle fast verbraucht ist. (Siehe "4.8 Papiermangel-Funktion".)
- Papierende** ----- Wenn die Papierrolle verbraucht ist, wird der Papiersensor in der Nähe des Druckkopfs aktiviert, um den Druck zu stoppen. Siehe "4.7 Papierende-Funktion".
- Etikettenpapierfehler** ----- Tritt auf, wenn Thermalpapier oder nicht-vorschriftsmäßiges Etikettenpapier eingesetzt wird, wenn Etikettenpapier gewählt ist. Die parallele Schnittstelle gibt BUSY und FAULT aus, und die serielle Schnittstelle gibt DTR aus.

3. FEED-Schalter

Siehe "4.6 FEED-Schalterfunktion".

4.12 Rot/Schwarz-Druck (Vorsichtsmaßnahmen)

(1) Papiersorten

Das rote und schwarze Zweifarb-Thermalpapier ändert seine Farbe durch Steuerung der am Thermalkopf angelegten Energie. Es ist grundsätzlich in zwei Typen unterteilt, entsprechend der Farbentwicklungsreihenfolge. Wählen Sie eine davon entsprechend Ihrer Applikation.

1. Auf Rot basiertes zweifarbiges Thermalpapier (PB670: MITSUBISHI PAPER MILLS)

Rotdruck (Niedrigenergie) → Schwarzdruck (Hochenergie)

2. Auf Schwarz basiertes zweifarbiges Thermalpapier (735FA: RICOH)

Schwarzdruck (Niedrigenergie) → Rotdruck (Hochenergie)

(2) Hochenergie-Druckrate

Hochenergiedruck (Schwarzdruck auf rot-basiertem Papier oder Rotdruck auf schwarz-basiertem Papier) erfordert die Anwendung von hoher Energie am Thermalkopf. Zum Schutz der Lebensdauer des Thermalkopfes verwenden Sie die folgende Druckrate als Richtlinie; verwenden Sie die Festteilungs (6-Teilung) Methode.

1. Kontinuierlicher Druck mit nur hoher Energie : 6% oder weniger
2. Gemischter kontinuierlicher Druck mit niedriger und hoher Energie : 30% oder weniger der Standarddruckrate von 12.5%
3. Druckrate pro Punktzeile : 50% oder weniger

(3) Minimale Punkte für Hochenergiedruck

Wenn Hochenergiedruck verwendet wird, ist der empfohlene minimale Bereich 3 Punkte (Länge) × 3 Punkte (Breite) oder mehr. Je nach der eingestellten Druckdichte, des verwendeten Papiers oder der Druckzeichen kann eine ausreichende Änderung des Farbtons auch bei Hochenergiedruck nicht erzielt werden.

(Zeichen wie [, !, ', (, ;, - Schriftart B mit kleiner Punktmatrix)

Es wird empfohlen, bei solchen Druckaufgaben doppelbreite Zeichen und doppelhohe Zeichen zu verwenden.

VORSICHT

- 1) Wenn Hochenergiedruck kontinuierlich bei hoher Umgebungstemperatur ausgeführt wird, erhitzt sich der Thermalkopf schneller, und die Schutzschaltung wird aktiviert, so daß der Druck häufiger gestoppt wird. Beachten Sie immer die Arbeitstemperatur und Druckrate.
- 2) Wenn eine Strichcode auf dem 2-Farb-Papier gedruckt wird, können beide Farben im Normaldruck erscheinen, und der Hochenergiedruck oder der Strichcode können nicht richtig von einem Strichcodeleser gelesen werden. Bei der Arbeit mit 2-Farbenpapier dies immer beachten.
- 3) Nicht normalen Hochenergiedruck auf Einzelfarbpapier (normalem Thermalpapier) ausführen. Dadurch kann die Lebensdauer des Thermalkopfes oder die Druckqualität beeinträchtigt werden.
- 4) Zur Einstellung siehe Befehle (DC3: Switching the Red/Black Printing)

5. DIP-SCHALTEREINSTELLUNG

5.1 Lage der DIP-Schalter

1. Das Gerät ausschalten.
2. Die Druckerabdeckung entfernen, und die Papierrolle herausnehmen. (Der Schalter befindet sich unter der Papierrolle.)
3. Es gibt 2 Schalter (8polig und 4polig) für die serielle Schnittstelle, und 1 Schalter (8polig) für die parallele Schnittstelle.

5.2 DIP-Schalterfunktion

DS1	No.	Funktion	ON	OFF	Beim Versand
	1	PNE-Wahl	Aktiviert	Deaktiviert	ON
	2	CR-Umschalten	LF-Betrieb	Ignoriert	OFF
	3	Druckdichte	Siehe Tabelle 1		OFF
	4				OFF
	5	Papierwahl	Etikettenpapier	Thermalpapier	OFF
	6	Autoladen	Aktiviert	Deaktiviert	ON
	7	DTR/DSR, XON/XOFF	XON/XOFF	DTR/DSR	OFF
	8	Japanische Schriftcode-Wahl	S-JIS	JIS	OFF

* DS1-7 : Nur für serielle Schnittstelle aktiviert. Für parallele Schnittstelle deaktiviert.

DS2 (Nur für serielle Schnittstelle)

No.	Funktion	ON	OFF	Beim Versand
1	Einstellung für Baudrate und Parität	Siehe Tabelle 2		OFF
2				OFF
3				OFF
4				OFF

Tabelle 1

	Leicht	Standard	Leicht Dunkel	Dunkel
DS1-3	OFF	ON	OFF	ON
DS1-4	OFF	OFF	ON	ON

Tabelle 2

DS2-4	DS2-3	DS2-2	DS2-1	Parität	Baudrate
OFF	OFF	OFF	OFF	Keine	9,600 bps
OFF	OFF	OFF	ON	Keine	1,200
OFF	OFF	ON	OFF	Keine	2,400
OFF	OFF	ON	ON	Keine	4,800
OFF	ON	OFF	OFF	Keine	9,600
OFF	ON	OFF	ON	Keine	19,200
OFF	ON	ON	OFF	Ungerade	1,200
OFF	ON	ON	ON	Ungerade	2,400
ON	OFF	OFF	OFF	Ungerade	4,800
ON	OFF	OFF	ON	Ungerade	9,600
ON	OFF	ON	OFF	Ungerade	19,200
ON	OFF	ON	ON	Gerade	1,200
ON	ON	OFF	OFF	Gerade	2,400
ON	ON	OFF	ON	Gerade	4,800
ON	ON	ON	OFF	Gerade	9,600
ON	ON	ON	ON	Gerade	19,200

5.3 Jumperdraht-Funktion

Die Jumperdrähte sind werksseitig vor dem Versand eingestellt. Die folgende Liste zeigt die grundlegende Einstellung beim Versand. Prüfen Sie die Einstellungen mit dem Selbsttest.

Jumperdrähte

No.	Funktion	Kurz	Offen	Bei Versand
J1	Internationale Zeichen	Siehe Tabelle 3		Kurz
J2				Kurz
J3				Kurz
J4	Datenbitlänge	7 Bit	8 Bit	Offen
J5	Nicht verwendet	–	–	Offen
J6	Etikett-Erkennung	Schwarze Markierung	Etiketten-Abstand	Offen
J7	Nicht verwendet	–	–	Offen
J8	Kommunikationsfehler-Markierung	Ignoriert	"?" gedruckt	Offen

* J4 : Nur serielle Schnittstelle. Für parallele Schnittstelle deaktiviert.

* J5 bis J7 : Nicht die werksseitigen Einstellungen verändern.

Tabelle 3

No.	USA	Frankreich	Deutschland	Großbritannien	Dänemark - I	Schweden	Italien	Japan
J1	Kurz	Offen	Kurz	Offen	Kurz	Offen	Kurz	Offen
J2	Kurz	Kurz	Offen	Offen	Kurz	Kurz	Offen	Offen
J3	Kurz	Kurz	Kurz	Kurz	Offen	Offen	Offen	Offen

VORSICHT:

- 1) Niemals die Stellungen der Jumperdrähte ändern.
- 2) Wenn die Einstellungen verändert werden sollen, vorher die Vertretung des Herstellers kontaktieren.
- 3) Niemals das Gehäuse des Druckers zerlegen. Dadurch können Betriebsstörungen und andere Probleme hervorgerufen werden.

9. WARTUNG UND KUNDENDIENST

Für Informationen über Wartung und Kundendienst wenden Sie sich bitte an unseren Händler.

